

**ANSYS**<sup>®</sup>

# ADVANTAGE<sup>™</sup>

Excellence in Engineering Simulation

VOLUME VII | ISSUE 2 | 2013

## SPOTLIGHT ON ROBUST DESIGN AND PRODUCT INTEGRITY



**12**  
In-Depth Solution

**16**  
Powered by  
Innovation

**22**  
Sound Success



Cray builds innovative systems and solutions enabling engineers to meet existing and future simulation and analytics challenges. Leveraging years of experience developing the world's most advanced supercomputers, Cray brings you a comprehensive portfolio of high performance computing systems (HPC), storage and Big Data solutions delivering unrivaled performance, efficiency and scalability.



[www.cray.com](http://www.cray.com)

**W**elcome to *ANSYS Advantage!* We hope you enjoy this issue containing articles by ANSYS customers, staff and partners. Want to be part of a future issue? The editorial team is interested in your ideas for an article. Contact us.

The Editorial Staff, *ANSYS Advantage*  
[ansys-advantage@ansys.com](mailto:ansys-advantage@ansys.com)

**Executive Editor**  
 Fran Hensler

**Managing Editor**  
 Chris Reeves

**Editors**  
 Erik Ferguson  
 Kara Gremillion  
 Mark Ravenstahl  
 Brenda Westcott

**Editorial Advisor**  
 Tom Smythman

**Editorial Contributor**  
 ANSYS North America  
 Support and Services

**Art Directors**  
 Ron Santillo  
 Dan Hart

**Distribution Manager**  
 Justin Nescott

**Design**  
 Wall-to-Wall Studios, Inc.

**Ad Sales Manager**  
 Helen Renshaw

**Realize Your Product Promise®**

ANSYS is dedicated exclusively to developing engineering simulation software that fosters rapid and innovative product design. ANSYS technology enables you to predict with confidence that your product will thrive in the real world. For more than 40 years, customers in the most demanding markets have trusted our solutions to help ensure the integrity of their products and drive business success through innovation.

ANSYS, Inc.  
 Southpointe  
 275 Technology Drive  
 Canonsburg, PA 15317  
 U.S.A.

For ANSYS, Inc. sales information,  
 call 1.866.267.9724.

Email the editorial staff at  
[ansys-advantage@ansys.com](mailto:ansys-advantage@ansys.com).  
 For address changes, contact  
[AdvantageAddressChange@ansys.com](mailto:AdvantageAddressChange@ansys.com).

Neither ANSYS, Inc., nor Wall-to-Wall Studios, Inc., guarantees or warrants accuracy or completeness of the material contained in this publication.

ANSYS, ALinks, Ansoft Designer, Aqwa, Asas, Autodyn, BladeModeler, CFD, CFX, Chip Power Module (CPM), Chip Thermal Model (CTM), DesignerRF, DesignerSI, DesignModeler, DesignSpace, DesignXplorer, Engineering Knowledge Manager (EKM), Explicit STR, Fatigue, Fluent, Full-Wave SPICE, HFSS, ICEM CFD, Icepak, Icepro, Maxwell, Mechanical, Mesh Morpher, Multiphysics, Nexxim, Optimetrics, ParICs, PathFinder, PExprt, Polyflow, PowerArtist, PowerArtist Calibrator and Estimator (PACE), Professional, Q3D Extractor, QuickEye, Realize Your Product Promise, RedHawk, Rigid Dynamics, RMXprt, RTL Power Model (RPM), SCADE Display, SCADE Lifecycle, SCADE Suite, SCADE System, Sentinel, S/wave, Simplorer, Simulation-Driven Product Development, Solver on Demand, Structural, Super-Compact, TGrid, Totem, TPA, TurboGrid, Vista TF, VeriEye, WinIQSIM, Workbench, and any and all ANSYS, Inc. brand, product, service, and feature names, logos and slogans are registered trademarks or trademarks of ANSYS, Inc., or its subsidiaries located in the United States or other countries. ICEM CFD is a trademark licensed by ANSYS, Inc. LS-DYNA is a registered trademark of Livermore Software Technology Corporation. nCode DesignLife is a trademark of HBM nCode. All other brand, product, service, and feature names or trademarks are the property of their respective owners.



## KEEPING YOUR PRODUCT PROMISE

**Every product represents a promise — a commitment to reliable, robust performance. ANSYS helps you honor that commitment with industry-leading design exploration capabilities that deliver product integrity, quickly and cost-effectively.**

**By Barbara Hutchings, Director,  
Strategic Partnerships/HPC Strategy, ANSYS, Inc.**

**I**n today's hyper-competitive, hyper-connected business landscape, product integrity has never been more critical. As recent headlines attest, the financial cost of product failure can have a major impact on a company's bottom line — eroding current profit margins and impacting future financials as potential warranty costs are built into the forecast. There are other long-term costs of product failures that may be less tangible but equally important. Today, thanks to the expansion of social media, a single dissatisfied customer can share his or her views with the world in seconds, via a single mouse click. Though harder to measure than warranty costs, negative product reviews can cause irrevocable damage to any manufacturer's hard-won brand equity.

To make things even more challenging, product reliability is not the only imperative that engineering teams face today. With shorter and shorter product lifecycles — and an increased level of product customization — engineers are pressured to produce more designs, faster than ever. The rise of smart products, with their plethora of electronic components, has taken design complexity to a level we could not have imagined even a decade ago.

### **How can engineers hope to combine unprecedented design speed and sophistication with an unwavering commitment to product integrity?**

How can engineers hope to combine unprecedented design speed and sophistication with an unwavering commitment to product integrity? The answer lies not just in leveraging engineering simulation — but in applying simulation in a new way that considers a wide range of real-world operating conditions, including multiple physical effects, quickly and cost-effectively. Simulation can also consider the impact of material property variations and manufacturing tolerances that affect product life, production and cost. By using simulation to understand how products will actually perform under a broad spectrum of real scenarios, engineers can reduce design uncertainty and the risk of failure — leading to a much higher probability that product promises can be kept.

At ANSYS, we call this reliability-driven product development focus “robust design.” Pratt & Whitney has coined the term “design for variation,” while other industry leaders reference “design for six sigma.” Whatever name it takes, design for product integrity is a pressing engineering imperative today, spanning every industry, product and engineering discipline.

ANSYS has made a sustained investment in developing a parametric, persistent computer-aided engineering (CAE) platform to support our customers' robust design initiatives. The parametric simulation capabilities of ANSYS software allow engineers to easily

vary a wide range of parameters — including geometry, material properties, model controls and operating conditions — to identify those few critical areas that could jeopardize product integrity. ANSYS has also committed to making it easier and more straightforward to integrate multiple physics in this parametric approach, which is essential because design failures often come as a result of physical interactions that would be missed in a single-physics design approach.

High-performance computing (HPC) is an enabler for robust design; the ability to consider multiple design ideas requires significant computational throughput. Our customers can achieve high throughput because ANSYS software is optimized to run fast and deliver outstanding scaling on today's multicore processors. With the latest release, we have innovated our HPC licensing to enable parametric analyses to be performed simultaneously — and more affordably — using parametric HPC job scheduling.

While robust design is growing as a strategic imperative, many engineering teams still express doubts about their ability to adopt this far-reaching, yet highly targeted, method of product development. The good news is that simulation software improvements are making it easier, faster and more cost-efficient than ever for every engineer to embrace the concept of robust design. At ANSYS, we are making a promise to continue our solution improvements until robust design becomes not just the leading practice, but the industry standard. By keeping this promise, we hope to help you keep your own essential promises. ▲



6



16



26

**FEATURES**

**6**  
**BEST PRACTICES**

**Avoiding Small Mistakes — and Huge Costs**

Robust design practices using engineering simulation help the world’s most innovative companies to protect product integrity and identify errors early — saving warranty costs, reputation damage and lost customers later.

**12**  
**OIL AND GAS**

**In-Depth Solution**

Technip automates evaluation of 20,000 simulation runs to ensure that subsea pipe structures can survive worst-case scenarios.

**16**  
**THOUGHT LEADER**

**Powered by Innovation**

Known for game-changing product innovations, Pratt & Whitney has relied on engineering simulation to fuel its design process for over 35 years. Al Brockett, former vice president of engineering module centers, discusses the role of robust design in delivering revolutionary new products with a high degree of confidence.

**22**  
**AUTOMOTIVE ELECTRONICS**

**Sound Success**

JVC KENWOOD Corporation employs robust design practices to develop innovative automotive speaker technology.

**26**  
**MARINE**

**A Perfect Fit**

Researchers develop an automated process for optimizing marine structural components.

**30**  
**ANALYSIS TOOLS**

**Designing Robust Electronics Systems**

Parametric simulation and high-performance computing ensure that engineers develop reliable electronic serial interconnects.

**34**  
**BEST PRACTICES**

**Robust Design for Integrated Circuits**

A broad range of tools is required to meet reliability goals for robust electronic systems.



38



44

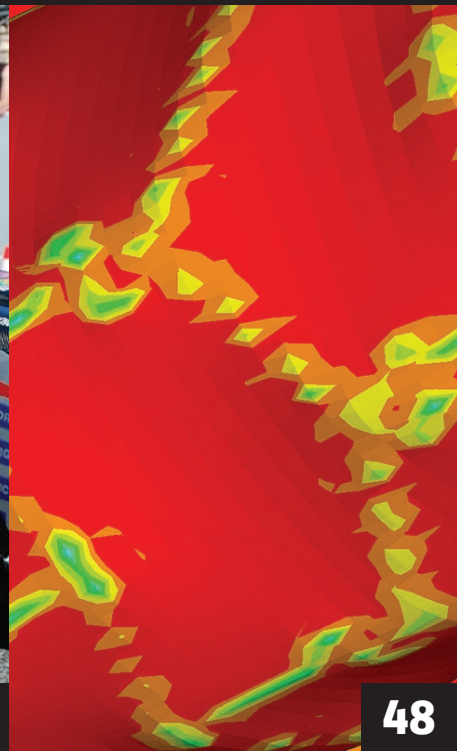

48

## SIMULATION@WORK

38

ENERGY

### Power for a Sustainable Future: Reducing Downtime

Simulation helps to improve productivity, performance and engineering innovation at a PTT gas separation plant.

40

ELECTRONICS

### The Heat is On

Toshiba improves product reliability and decreases development time through electromagnetic-thermal-stress coupling.

## DEPARTMENTS

44

ACADEMIC

### Formula for Racing Success

Students apply robust design principles to develop a highly competitive race car.

48

ACADEMIC

### Cardiovascular Engineering

As engineering and medicine converge, researchers are making gains in understanding and treating causes of cardiovascular disease.

54

TECH TIP

### Leader of the Pack

ANSYS HPC Parametric Pack licensing enables the quick solution of parametric simulations.



## ABOUT THE COVER

Vessels like Technip's *Deep Energy* install equipment that must not only withstand the challenges of the deep but also variations encountered during installation itself. Learn more on page 12. PHOTO COURTESY TECHNIP.

# Simulation in the News

## CFD: SHAPING THE MEDICAL WORLD

*Desktop Engineering*  
[deskeng.com](http://deskeng.com), April 2013

When fluids are involved in healthcare R&D, fine-tuned simulation software helps engineers to develop new medical techniques and advance current technologies. CFD projects include modeling blood circulation and stent placement, developing oxygen masks that improve a patient's ability to speak clearly, and designing blood flow pumps that improve surgery results. For example, researchers using ANSYS CFD employ actual patient scan data as a basis for simulation, providing doctors with accurate, patient-specific information that can limit the number of required tests.

## ELECTRIC DRIVE MOTORS ANALYZED AND OPTIMIZED FASTER

*Elektroniknet*  
[elektroniknet.de](http://elektroniknet.de), March 2013

Hybrid and electric vehicles are on the rise worldwide, but motor development challenges limit continued growth. Engineers must solve structural, thermal and electromagnetic problems that affect performance, reliability and electric engine costs. Engineers employ ANSYS tools in an effort to create robust designs as they move from traditional trial-and-error to simulation-based development.

**Engineers must solve structural, thermal and electromagnetic problems that affect performance, reliability and electric engine costs.**

## SMARTPHONES, SMART INDUSTRY

*Le Cercle*  
[lecercle.lesechos.fr](http://lecercle.lesechos.fr), February 2013

Revolutionized by simulation, the smart products industry has grown rapidly. Product lifecycles are becoming shorter and customers more demanding. Companies limit costly physical tests, accelerate time to market, and innovate in a virtual environment with simulation. Multidisciplinary teams optimize systems and performance early in the design stage, leading to more robust product improvements. Barry Christenson of ANSYS discusses how simulation should be leveraged through the entire design phase, including basic modeling, internal electronics development and final design of products.

**Simulation should be leveraged through the entire design phase.**

## ANSYS ACQUIRES EVEN

*ansys.com*, April 2013

ANSYS completed its acquisition of Evolutionary Engineering AG (EVEN), developer of ANSYS Composite PrepPost. Composites simulation is rapidly growing with applications across many industries, fostering the need for new design, analysis and optimization technology. The acquisition emphasizes the high priority that ANSYS places on this emerging technology.

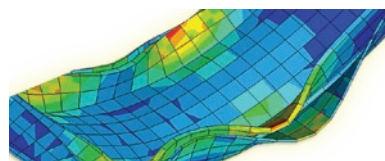

▲ Simulation of advanced composites design

## TU DELFT STUDENTS AND STAFF TO USE SIMULATION SOFTWARE ON PERSONAL LAPTOPS

*Engineers Online*  
[engineersonline.nl](http://engineersonline.nl), February 2013

Around the world, students gain hands-on experience with ANSYS software through the new Academic Student package. The Technical University of Delft in The Netherlands extended licenses tenfold for students and staff to enable education outside the classroom. Students can prepare for professional careers by spending more time using ANSYS, while staff benefit with expanded research opportunities.

## FACE, ARINC, DO-178C AVIONICS STANDARDS HELP U.S. DOD'S VISION OF REUSABLE TECHNOLOGY TO TAKE OFF

*Military Embedded Systems*  
[mil-embedded.com](http://mil-embedded.com), March 2013

Historically, avionics hardware and software systems were developed for unique requirements. But now it is no longer cost-effective to develop customized systems for specific applications, and the DoD is seeking to reduce development time and costs. ANSYS subsidiary Esterel is a member of the Future Airborne Capability Environment (FACE) Consortium to develop technologically appropriate software computing environment standards. FACE promotes product lines that are reusable across different air platforms, which reduces costs and improve aeronautical electronics systems.

**FACE develops technologically appropriate software computing environment standards for use by the DoD.**

## DESIGNING TO MEET 54.5 MPG BY 2025

Visual.ly

visual.ly/fuel-efficiency, March 2013

The federal government introduced fuel-economy and carbon-emission standards that force automotive manufacturers to develop new technologies and improve current designs to increase mpg — from 23.2 to 54.5 mpg by 2025. Simulation optimizes the design while eliminating extra design stages, helping manufacturers quickly produce advanced vehicles. Automotive experts at ANSYS highlighted key areas of improvement for the industry in an easy-to-understand infographic that illustrates how manufacturers might meet the 2025 deadline.

► The infographic compares old and new methods of vehicle design and how simulation can eliminate steps to increase optimization speed.

## ELECTRICAL HEATING METHODS FOR OIL RESERVOIR STIMULATION

Oil & Gas Monitor

oilgasmonitor.com, March 2013

Increased demand for oil has pressured energy companies to explore unconventional resources while limiting environmental damage. Electromagnetic heating of oil sands holds great promise for additional production. Ahmad Haidari of ANSYS details how energy companies apply simulation software to determine the most efficient way to extract the oil in this manner. Traditional open-pit mining and steam-assisted gravity drainage methods are expensive and harmful to the environment. New techniques to extract petroleum from oil sands incorporate simulation to determine pipe placement, ideal heating conditions, and refinery positioning. By replacing traditional mining methods, simulation-based drilling can lead to lower environmental impact, improved quality of extracted oil, and decreased production costs.

## ANSYS HFSS FOR ECAD

ansys.com, May 2013

ANSYS HFSS software now includes a 3-D electrical layout interface in addition to its traditional 3-D modeler. Engineers designing high-performance electronic equipment need the power of HFSS for accurate electromagnetic extraction but are typically not familiar with 3-D modeling paradigms. Designed specifically for working with layout data, the ANSYS HFSS for ECAD interface will help to greatly simplify the analysis setup for PCB, electronic packages and more. This 3-D electrical layout is now included with all base HFSS products.

# Fuel Efficiency

As the EPA demands 54.5 mpg by 2025, auto manufacturers are focusing on these design and technology challenges to meet standards.

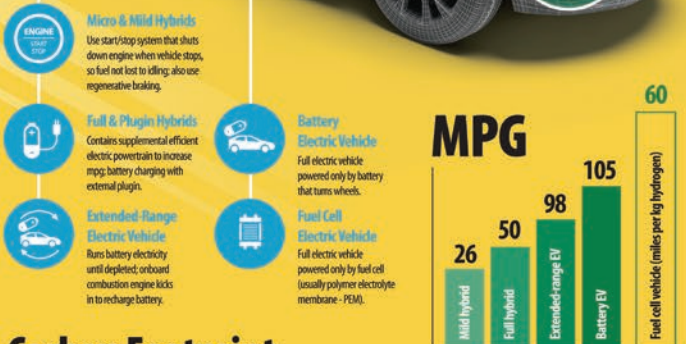
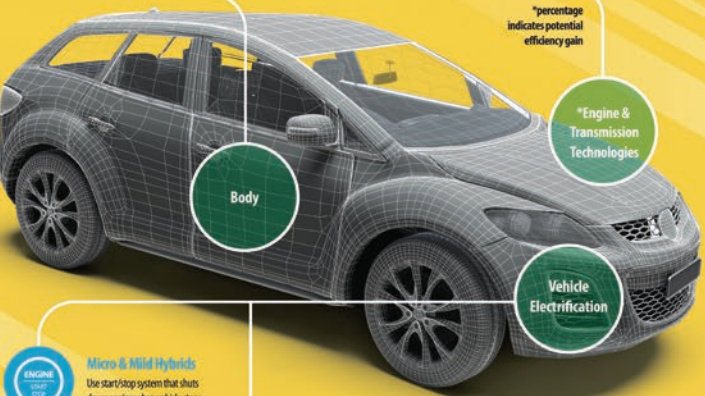
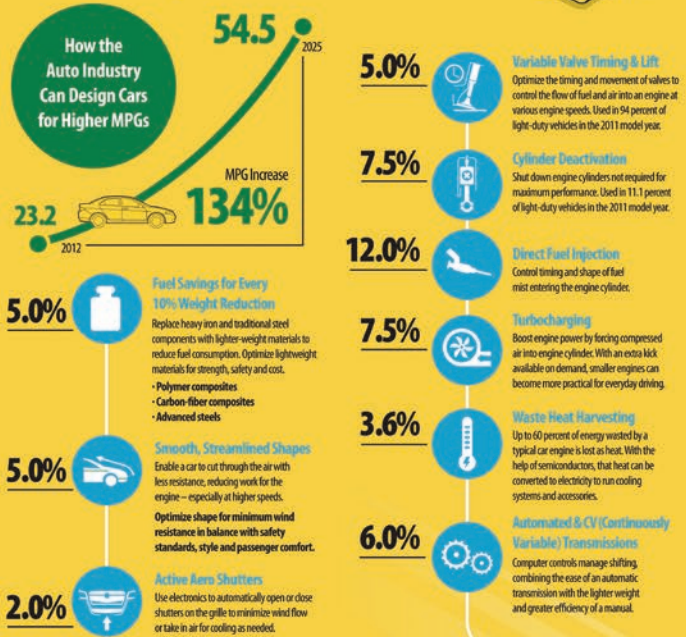

## Carbon Footprint

Better fuel efficiency means a smaller carbon footprint and less pollution.

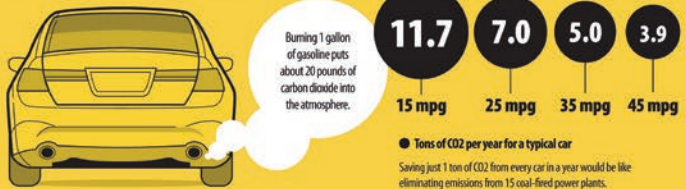

# Avoiding Small Mistakes and Huge Costs

A high-speed photograph of a white smartphone splashing into clear water. The phone is tilted, and the screen is a vibrant blue. The water is splashing around the phone, creating many bubbles and droplets. The background is white.

**Robust design practices using engineering simulation help the world's most innovative companies to protect product integrity and identify errors early — saving warranty costs, reputation damage and lost customers later.**

By **Wim Slagter**, Lead Product Manager, ANSYS, Inc.



**D**espite the many incredible advances we've seen in the practice of engineering, no product or process is guaranteed to always perform as intended. Regardless of how carefully we engineer, there are still natural material variations that affect product outcomes down the road. Although manufacturing has become highly automated and standardized, tolerances and variations are unavoidable in sourcing, production, distribution, delivery, installation and degradation over a product's life. Perhaps the greatest source of variation and risk lies in the physical world in which a product must perform — with its wide range of user behaviors, temperature extremes, and range of structural, fluidic and electromagnetic forces occurring over time.

Amid all the uncertainties of the end-to-end product lifecycle, it is challenging to ensure the kind of consistent, reliable performance that supports product integrity and protects brand reputations. Yet today, there are few tasks more critical to ensuring long-term profitability.

Product failures deliver an enormous financial setback in a number of ways. First, there are the obvious immediate bottom-line impacts of recalls and warranty payouts. Despite all our engineering sophistication, today's warranty costs alone can account for up to 10 percent of total sales. According to *Warranty Week*, U.S.-based manufacturers spent \$24.7 billion on claims in 2011, up from \$23.6 billion in 2010. Those same manufacturers held \$36.6 billion in their warranty reserve funds at the end of 2011, up from \$33.8 billion at the end of 2010.

But as manufacturers increasingly apply robust design tools and processes, these numbers are improving. Warranty claims in 2012 dropped 3 percent to just under \$24 billion, while sales of products

**U.S. manufacturers spent \$24.7 billion on claims in 2011, up from \$23.6 billion in 2010.** 

## **Faster and more frequent product introductions may compromise the ultimate quality and reliability of product designs.**

with warranties increased that year — and *Warranty Week* reported that companies are using technology to work smarter and reduce these costs.

Even so, warranty costs are still significant — and they represent only the short-term effect of product failure. Over the longer term, the cost of lost customers, negative publicity and bad product reviews can be even more devastating. The internet brings our entire world into close proximity, so unhappy customers can always find a product alternative — as well as share their dissatisfaction instantly with the world via social media. In this extremely competitive, ultra-connected and highly scrutinized environment, one fact is clear: Manufacturers need to avoid even the smallest design mistake, because of the risk of devastating short- and long-term costs.

### **ROBUST DESIGN: AN ENGINEER'S MOST VALUABLE TOOL**

If variability and uncertainty represent undeniable realities, how can engineers hope to manage these risks? The answer lies in considering, from the earliest design stage, the widest possible range of material properties, manufacturing processes, real-world operating conditions, and end-user behaviors. By bringing many sources of variation and uncertainty into the product development process, engineers can produce the most robust design.

When engineers use conventional simulation practices, they assume that all inputs are known — and they compute the product's response, optimizing their designs to maximize desired performance characteristics at a single design point. Conversely, robust design assumes that no one fully understands every possible input. Simulation is applied in a

parametric way to identify the best possible overall product design by considering many sources of uncertainty and variation that otherwise would not be taken into account.

Robust design empowers engineers to predict and control performance outcomes in the face of dozens, hundreds or even thousands of multiphysics inputs that products are subjected to every day. Whatever their industry or specific product development challenge, to ensure ultimate product integrity, engineering teams must progress from examining a single design point to exploring hundreds, thousands or tens of thousands of design points.

Today, businesses in every industry feel increasing pressure to launch new product models that keep pace with both competitors and changing market needs. However, faster and more frequent product introductions may compromise the ultimate quality and reliability of product designs.

In a recent ANSYS survey, when almost 3,000 respondents were asked to name the biggest pressures on their design activities, 52 percent cited “reducing the time required to complete design cycles.” At the same time, 28 percent of respondents named “producing more reliable products that result in lower warranty-related costs” as a chief concern.

Comparing results from this survey to a study ANSYS commissioned in 2011, there is nearly a threefold increase in the number of respondents who feel pressure to design products that incur lower costs from warranty claims, recalls and other consequences of product failure. In 2013, respondents also reported much greater pressure to find new ways to differentiate their products from competitors' offerings, particularly in terms of higher quality.

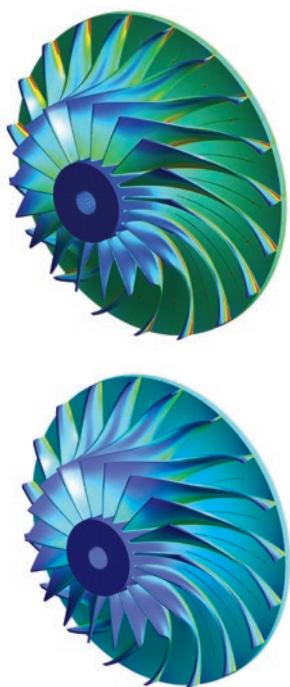

▲ Because of turbomachinery design complexities, this engineering field is fairly advanced in applying robust design. An academic team at the Dortmund University of Applied Sciences and Arts in Germany combined ANSYS Workbench with optiSLang — an efficient software tool for sensitivity analysis — to optimize a radial compressor. The goal was to retain efficient fluid flows while strengthening the blades to withstand greater stresses. Traditional simulations would have focused on a single, rotationally symmetrical sector of the compressor; in this case, the team used multiphysics structural-CFD parametric analysis to simulate stresses and flows for a complete 360-degree geometry. By quickly identifying the critical stress points at the outlet of the impeller, the team optimized the compressor geometry. Stress was reduced by an impressive 40 percent, while efficiency was maintained. Original design (top), optimized design (bottom)

Engineering simulation addresses this complex challenge by providing a systematic way to quickly validate, modify or discard new product ideas based on their likely performance. While it would be impossible to physically test for every source of variation, engineering simulation makes stringent, reliability-focused product testing accessible and cost-effective via robust design technology.

### DEMOCRATIZING ROBUST DESIGN VIA TECHNOLOGY

As more R&D teams discover the central role that engineering simulation plays in

ensuring ultimate design robustness, the good news is that a perfect storm of technology improvements has helped to make simulation faster, more streamlined and more accessible than ever. The incredible growth in high-performance computing (HPC) capabilities has enabled even the most computationally large problems to be solved rapidly via parallel processing, distributed solving, automation and other capabilities.

HPC is essential to the growing “democratization” of robust design practices because this reliability-focused product development method relies on broad systems-level analyses that study multiple forces acting on multiple components. Automated, parametric studies make it easy for engineers to understand the impacts of the smallest design changes on systems-level performance and isolate the most critical design points — yet these multiphysics, multi-run simulations consume enormous amounts of computing power, making HPC a key enabler.

Continuing enhancements to ANSYS software have helped to create this perfect storm, placing robust design tools in the hands of more and more engineers every day. In matching the speed and power of HPC with smarter, more targeted ways to manage and solve large multiphysics problems, ANSYS has emerged as a leader in the growth of robust design.

### TOOLS ENABLE ROBUST DESIGN

While the benefits of simulation-driven, reliability-focused design processes are evident, many engineering teams seem hesitant to leverage today’s sophisticated robust design tools. The survey conducted by ANSYS found that 22 percent of respondents have not engaged in parametric simulation because they perceive it as too labor-intensive, with turnaround times that are prohibitively long. There is also a mistaken belief that the costs of simulation-driven robust design are prohibitively high, especially related to software licensing.

However, improvements in the ANSYS Workbench platform help to democratize robust design practices by supporting more persistent parametric simulations with an increasing degree of automation. At the same time, a parametric HPC licensing model makes robust design more scalable and cost-effective than ever.

Reaping the benefits of robust design requires a full array of software solutions, support and licensing agreements that address customer needs at every stage of the robust design journey. ANSYS assists customers throughout this journey, from parametric simulation and design exploration — including techniques such as response surface and design of experiments (DOE) — to goal-driven optimization and probabilistic optimization.

Typically, as customers recognize the impact of parametric studies on ultimate product integrity — as well as on design process time and cost-effectiveness — they are eager to take simulation usage to the next level. A number of key capabilities in ANSYS software make it easier for users to adopt robust design best practices that can reduce design process time and related costs.

### Automated Execution of Multiphysics Simulations

To increase workflow throughput, ANSYS software allows users to automatically investigate multiple, parametric design variations — all without programming. The Workbench project window provides a guide throughout the simulation process by working through the system from top to bottom. The entire process is also persistent: Engineering teams can streamline workflows by automatically propagating changes in geometry, meshing and physics without manual rework. Because a single physics is often not enough to understand the full design space, Workbench makes it easy to tie together multiple physics and create virtual prototypes with drag-and-drop simplicity, connecting physics with no scripting, file transfer or file conversion.

### Accurate, Reliable and Customizable Solver Technology

ANSYS software contains sophisticated numerics and robust solvers to ensure fast, accurate results for a nearly limitless range of engineering applications. Solvers are highly optimized to deliver outstanding parallel scaling on today’s multicore processors. To meet an organization’s present and future simulation and workflow process requirements, ANSYS software is readily customizable and extensible; users can implement their own specialty physics models, and the user environment can be

readily customized and scripted for establishing best practices and further workflow automation.

### Integrated Parameter Management

Workbench hosted applications support numerous variations that reflect a range of design and operating parameters — including CAD parameters, mesh settings, material properties, boundary conditions and derived result parameters. Parameters defined within the applications are managed from the project window, making it easy to investigate multiple variations of the analysis. From within the project window, a series of design points can be built up in tabular form and executed to complete a what-if study with a single operation.

### Integrated Design Exploration Capabilities

ANSYS DesignXplorer features a variety of DOE types that sample the design

space, allowing engineers to efficiently explore via a relatively small number of simulations. A response surface can be fitted to the results, making it possible to predict the value of every other design point within the design space. The DOE table of design points can be solved in batch mode on a local machine or remotely distributed for a simultaneous solve. ANSYS simulation software can be used in concert with many optimization partner solutions.

### Simultaneous Design-Point Analysis

Software from ANSYS supports robust design simulation practices with a more complete, more robust set of tools that enable simultaneous submission of multiple parametrically linked simulation jobs. The HPC Parametric Pack license amplifies the available licenses for individual applications (such as pre-processing, meshing, solving and post-processing), enabling simultaneous

execution of multiple design points — while consuming just one set of application licenses. The Remote Solve Manager (RSM) in Workbench allows users to submit multiple design-point jobs, with each job executing on multiple parallel processing cores and — if needed — via third-party job schedulers.

### Shape Optimization Accelerated by Morphing Capabilities

ANSYS software integrates morphing technology within the computational fluid dynamics (CFD) solver to solve a series of design points without manual creation of a new geometry and mesh. Developed with software partner RBF Morph, this groundbreaking technology allows the entire setup to be accomplished within ANSYS Fluent. Engineers define a series of shape parameters that form the basis of the design space, then the computational mesh is automatically morphed for each design point. The clear advantage of this approach is that geometry updates are not needed until after the final design is selected.

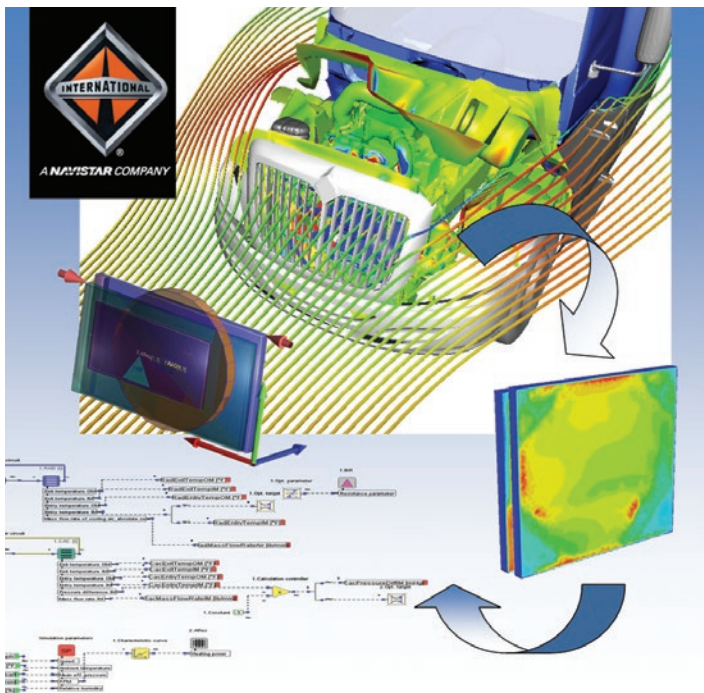

▲ Navistar has utilized ANSYS Fluent and KULI to develop a vehicle thermal optimization solution. This coupling methodology has improved thermal predictions and increased design turnaround time. Employing this process has given Navistar a competitive advantage in developing thermal solutions to meet increasingly stringent emission regulations. COURTESY NAVISTAR, INC.

### LEARN FROM THE LEADERS IN ROBUST DESIGN

This issue of *ANSYS Advantage* highlights the many benefits of taking a robust design approach. These real-world stories show the wide range of ways that leading engineering teams are applying robust design to address an equally diverse spectrum of pressing design challenges.

Technip, a leading supplier to the global energy industry, recently used DesignXplorer to automate 20,000 simulations aimed at modeling performance complexities of an undersea piping system. In an industry in which the cost of mistakes can be devastating, Technip now tells its customers, with confidence, that this equipment has been tested against every possible stress load.

Electronics leader JVC KENWOOD has employed robust design practices to develop innovative automotive speaker technologies. The company has reduced its overall product development cycle by 10 percent, increased product performance by 5 percent, and reduced the amount of materials in the typical speaker by up to 40 percent — a significant cost savings.

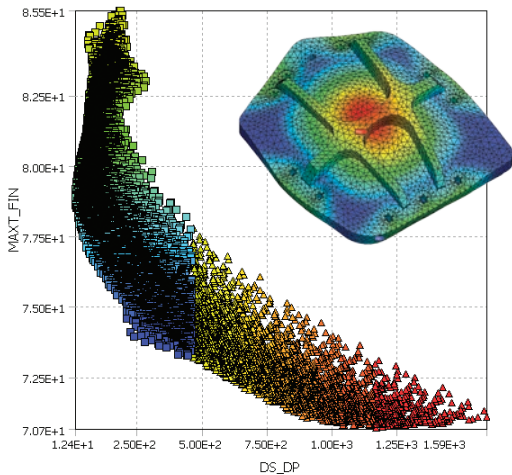

◀ Structural analysis and shape optimization of fuel cell end plates were performed to optimize stiffness within space limitations. After generating 10,000 virtual experiments using simulation, engineers created a scatter plot of performance requirements showing maximum temperature versus pressure drop. Dark blue squares represent data points that meet all design requirements and have minimal temperature.

COURTESY ADVANCED ENGINEERING SOLUTIONS.

This edition's thought leader is Al Brockett, who recently retired following a 35-year career leading the engineering team at Pratt & Whitney. The company has used a robust design methodology — which it calls design for variation — to achieve a 64 percent to 88 percent return on investment by reducing design iterations, improving manufacturability, increasing reliability, improving on-time deliveries and realizing other performance benefits. Brockett offers practical advice for other engineering teams interested in adopting robust design as a guiding principle.

### RENEW YOUR COMMITMENT TO PRODUCT INTEGRITY

Robust design delivers a variety of business benefits that can be customized to your organization's top-level strategic challenges — whether your pressing need is improving speed to market, launching a game-changing product innovation, or driving materials or manufacturing costs out of your processes. At its heart, however, robust design is focused on a much more critical deliverable: protecting product integrity. Unless your products perform as expected, under unpredictable real-world conditions, every single time, the other business benefits simply won't matter.

While ANSYS has invested significantly in robust design capabilities, such as parametric setup, persistent updates, and

## Robust Design and Smart Products: A Special Challenge

One of the biggest trends in engineering is the increased incorporation of smart electronic features that enable products to monitor and improve their own performance. From everyday devices like mobile phones to unexpected applications like wind turbines, the inclusion of smart technologies makes design robustness even more critical — but also more challenging to achieve.

Integrating electrical, mechanical, digital control and embedded software components into a single design can create an environment of technological chaos, in which it is difficult to isolate and address factors that truly impact systems-level performance. There may be thousands of requirements for a system, and these may be at odds with requirements at the component level. Typically, each engineering discipline works independently, functioning in isolation from each other and passing project information from one group to another in serial fashion. In many cases, mechanical engineering groups complete work and then forward tasks to electronic/electrical design engineering, which then forwards tasks to software engineering.

Each discipline works in silos, with individual design processes and nonintegrated design tools. As a result, engineers downstream in development have little opportunity to provide valuable input early in the cycle, and design deficiencies often are not uncovered until late in the process — when changes are costly and time consuming.

Simulating the complete system requires combining these engineering disciplines along with their models of varying orders of fidelity (3-D, 1-D and 0-D) and embedded software systems. ANSYS Simplorer — historically used for modeling power electronics and other electrical systems — is being adapted to address these complex multidomain, multitechnology problems. Simplorer supports design robustness by allowing engineers to incorporate ANSYS mechanical, fluid and electromagnetic software with circuit and system capability, as well as Esterel embedded software technology, to identify early-stage design issues that other simulation tools (or build-and-test methods) cannot detect.

DOE and HPC technologies, many engineering teams still are not leveraging engineering simulation to support design robustness. As you review this edition of *ANSYS Advantage*, perhaps you'll be inspired to renew your own commitment to product integrity by advancing robust design efforts via simulation.

Whether you are a beginner or an advanced user of robust design practices, ANSYS can assist you with building in product

integrity from the start. Based on our experience in supporting robust design initiatives with some of the world's leading engineering teams, we're confident that high-impact engineering simulation can help you make, and keep, the kinds of meaningful performance promises that establish your company as a true leader in product integrity. ▲

# Pratt & Whitney's robust design methodology has achieved a 64 percent to 88 percent ROI. ▶

## How to Evolve Your Simulation Practices Toward Robust Design

Establishing a robust design process is not a one-time event, but an evolution that occurs over time as simulation practices become increasingly sophisticated. As shown below, most organizations begin this journey by looking at a one-off design, single-physics analysis for validation purposes. As engineering teams begin to apply ANSYS solutions in a parametric manner, using techniques to visualize and interrogate the design

space, simultaneously executing multiple designs through multi-goal analyses, and looking at statistical variation of design input parameters, their design process drives towards optimization in a world of design input uncertainty — and they become ever more confident that their products will perform as expected in the real world.

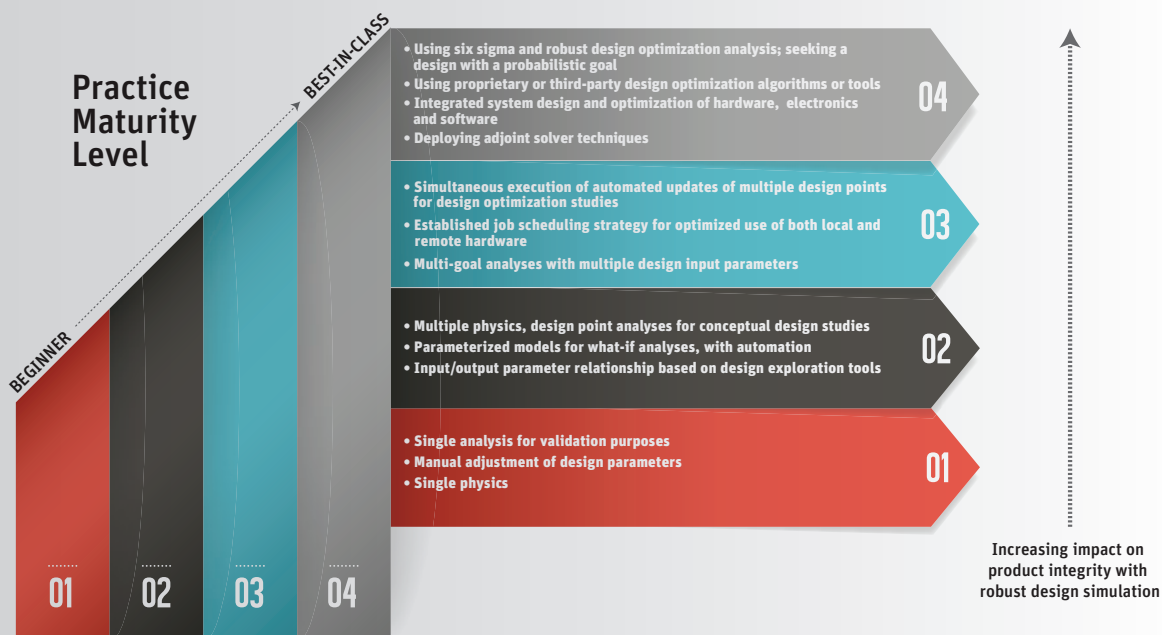

# In-Depth Solution

**Technip automates evaluation of 20,000 simulation runs to ensure that subsea pipe structures can survive worst-case scenarios.**

By Esen Erdemir-Ungor, Design Specialist, Technip, Houston, U.S.A.

**J**umpers are piping components of subsea oil production systems that connect one structure to another, such as for linking satellite wells to a manifold, the platform or other equipment. Designing these very important components is difficult because both of the connection points are free to move — within allowable limits — due to thermal expansion, water currents and other factors. Jumper designers need to evaluate every possible combination of movement, expansion and rotation to determine which combination applies the most stress to the jumper, then design the jumper to withstand it.

Technip recently designed four jumpers, each connecting a pipeline end termination (PLET) — the end connecting point of a pipeline — to the manifold of a producing well or another PLET. Technip is a world leader in project management, engineering and construction for the energy

industry. With facilities in 48 countries, the company operates a fleet of specialized vessels for pipeline installation and subsea construction.

## **LOADS ON THE JUMPER**

Undersea pipelines are governed by strict codes developed to ensure pipeline integrity to prevent an oil spill. The jumper needs to withstand loads applied to both ends of the pipe while keeping stress in the jumper within the limits specified by the code.

When oil or gas is transported in the pipeline, the pipeline undergoes thermal expansion, and this expansion is transmitted to the jumper. In this Technip application, thermal expansion was calculated to be a maximum of 40 inches in the x-axis and 30 inches in the z-axis. Further displacements of up to 2 inches in the x-, y- and z-axes were possible due to variation when the position of

the structures was measured and when the jumper was cut and assembled to its final size. Rotations of up to 5 degrees in either direction in the x- and z-axes were also possible. The net result was a total of three displacements and two rotations on each end of the jumper that needed to be considered at each extreme of its range of motion. To fully understand every load case that could be applied to the jumper, it's necessary to consider every possible combination of these 10 different variables, a total of 1,024 load cases.

Technip engineers had to take into account variability in the position of the PLET and manifold. There is a target location for the two structures, but the position can vary within the project-specified target box. As a result, the length of the jumper can be anywhere from 900 inches to 1,500 inches; furthermore, the gross angle of the jumper with respect to the PLET and manifold also can vary. This



PHOTO COURTESY TECHNIP.

# Using conventional analysis tools, it would be impossible for an engineer to solve this many load cases within a normal design cycle.

a relatively small number of load cases that they believe will generate the highest level of stress. But operators of wells and pipelines are becoming much more sensitive to potential hazards. In this project, the customer asked that every single load case be evaluated to make certain that the jumper could withstand the absolute worst case. Just a few years ago, such a task would take so long that organizations would rule it out for production jobs. But recent advances in optimization tools now make it possible to rapidly evaluate large numbers of design cases to ensure robustness.

## EXPLORING THE DESIGN SPACE

In this project, the first step was to create a simple jumper model in ANSYS DesignModeler based on a previous design. Engineers created three design

parameters to define the geometry of the jumper that could be varied to improve its performance. Parameters included the length of two vertical and one horizontal sections of pipe that constitute the core of the jumper (geometric parameters) as well as three displacement and two rotation parameters at each end of the jumper (mechanical parameters), with two possible values representing each extreme end of its range of motion.

As the first step of the design process, engineers set up a short simulation run to explore the design space. They selected a previous design as the starting point, and the geometric design parameters were allowed to vary over a limited range in increments of 1 foot. Engineers used the Design Points option in ANSYS DesignXplorer to select a subset of about 200 load cases. They

gross angle is important because it determines the angle at which thermal expansion is applied to the jumper. The position of the PLET and manifold are measured prior to jumper installation. The jumper is then cut and welded to the length and angle determined by the measurements just before it is installed. The engineering team addressed these variations by considering four different scenarios for the jumper: maximum length, minimum length, maximum gross angle and minimum gross angle. So a complete evaluation requires that the 1,024 load cases be evaluated for each of these four scenarios, resulting in a total of 4,096 load cases for each jumper design.

Using conventional analysis tools, it would be impossible for an engineer to solve this many load cases within a normal design cycle. The standard practice has been for experienced engineers to use their judgment and instinct to pick out

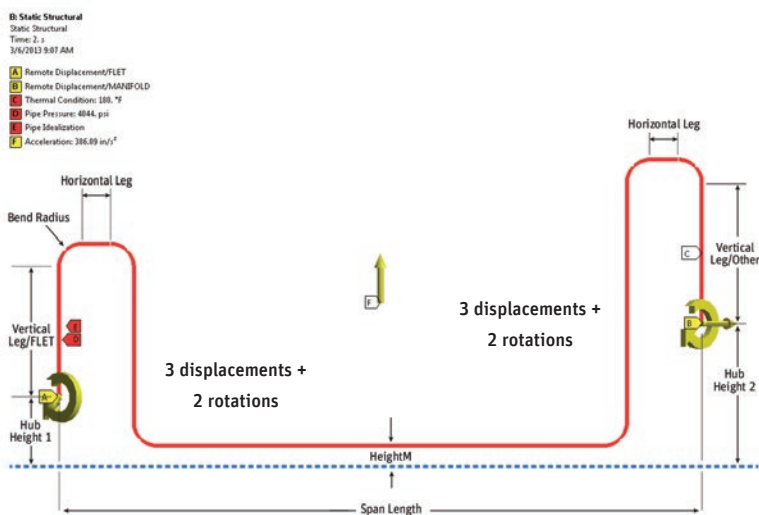

▲ Parameters were allowed to vary during optimization. The diagram shows loads that potentially can be applied to the jumper. Ten variables were applied to the remote displacements.

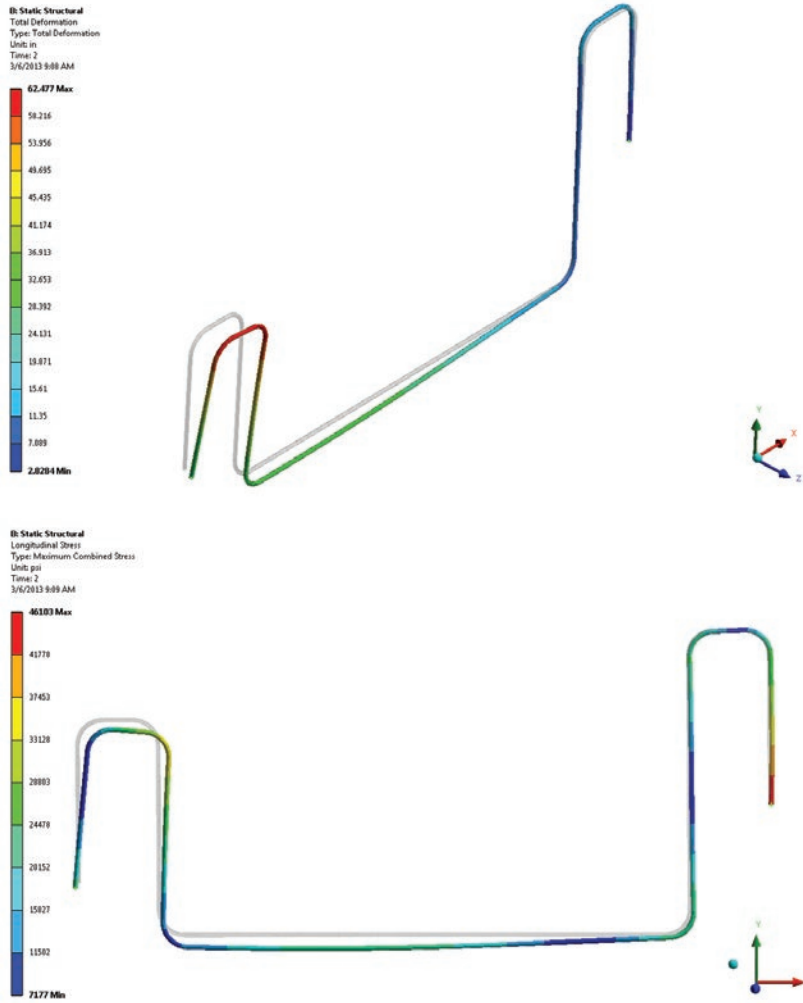

▲ Total deformation (top) and maximum combined stress (bottom) at true scale

Table of Results (DOE Design of Experiments)		Table of Results (DOE Design of Experiments)															
1	2	A	B	C	D	E	F	G	H	I	J	K	L	M	N	O	
1	Design of Experiments																
2	Static Structural (DOE)																
3	Static Structural (DOE)																
4	Static Structural (DOE)																
5	Static Structural (DOE)																
6	Static Structural (DOE)																
7	Static Structural (DOE)																
8	Static Structural (DOE)																
9	Static Structural (DOE)																
10	Static Structural (DOE)																
11	Static Structural (DOE)																
12	Static Structural (DOE)																
13	Static Structural (DOE)																
14	Static Structural (DOE)																
15	Output Parameters																
16	Static Structural (DOE)																
17	Static Structural (DOE)																
18	Static Structural (DOE)																
19	Static Structural (DOE)																
20	Static Structural (DOE)																
21	Static Structural (DOE)																
22	Static Structural (DOE)																
23	Static Structural (DOE)																
24	Static Structural (DOE)																
25	Static Structural (DOE)																
26	Static Structural (DOE)																
27	Static Structural (DOE)																
28	Static Structural (DOE)																
29	Static Structural (DOE)																
30	Static Structural (DOE)																

▲ The design of experiments capability in ANSYS DesignXplorer helped the simulation software to run thousands of load-case steps. Actual mechanical parameter ranges are shown.

created a table with these parameters within the DesignXplorer optimization tool. A Technip engineer gave the Update command to solve the model for every combination of values in the table. The first design point, with the first set of parameter values, was sent to the parameter manager in the ANSYS Workbench integration platform. This drove the changes to the model from CAD system to post-processing.

DesignXplorer used parametric persistence to reapply the setup to each combination of parameters while file transfer, boundary conditions, etc., remained persistent during the update. The new design point was simulated, and output results were passed to the design-point table where they were stored. The process continued until all design points were solved to define the design space. The outputs of each simulation run included the minimum and maximum bending stress, shear stress, axial stress and combined stress within the jumper. Technip engineers examined the results, looking particularly at the sensitivity of the outputs with respect to design parameters and whether their variation with respect to the design parameters was linear or nonlinear.

### DETERMINING THE WORST-CASE SCENARIO

As the second step, engineers fixed the mechanical parameters at the values that provided the worst results in the previous step with the goal of obtaining the geometric parameter set that could withstand the worst load combinations. Once the mechanical parameters were set at the current worst case (obtained from the first step), then the geometric parameters were allowed to vary over a greater range. Technip created a design-point table using the default settings in the design of experiments. Engineers employed goal-driven optimization for which the primary goals were that the stresses mentioned previously would not exceed allowable values. At the end of the second step, a set of geometric parameters that do not fail under the current worst-case scenario was obtained.

The third step confirmed that the optimized geometric parameter set would not have stresses higher than the allowable values under any possible load combination. Technip engineers created a design-point table using



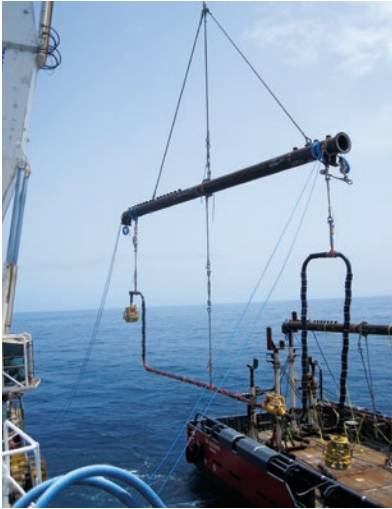

▲ Jumper installation

the two possible extreme values (minimum and maximum) for each mechanical parameter while fixing the geometric parameters at the values obtained in the previous step. Since there are 10 mechanical parameters, this resulted in 1,024 ( $2^{10}$ ) load cases. The Custom Design Point table option was used to import the 1,024 determined load cases. Engineers monitored the

design-of-experiments runs, and if, for any load combination, the allowable values were exceeded, the design-point update was stopped, then the mechanical parameters that produced high stress were set to the new worst-case scenario. This started the iterative process between the second and the third steps. When all the runs in the third step were completed successfully, so that the allowable values were not exceeded within the pipe and the reactions at the ends of the jumper did not exceed connector limits, engineers moved onto the fourth step.

The 1,024 load combinations for each of the other three scenarios discussed earlier were run using design of experiments for step four. When all the design criteria were met for all 4,096 possible load combinations, engineers deemed the optimized parametric set successful, and the design for the first jumper was finished.

For the second, third and fourth designs, Technip engineers started with the optimal design that had been determined for the first jumper. They ran this design against the 4,096 load cases for each of the other jumpers. The maximum stresses were not exceeded on the last three jumpers — for each jumper design, engineers ran only the 4,096 cases needed to prove that the design could withstand

every possible load case.

Variations in operating conditions may create uncertainty in subsea pipe structural design. Using parametric exploration and optimization tools from ANSYS, engineers checked the structural performance and integrity of these four jumpers over about 20,000 simulation runs. This capability will provide Technip with the significant competitive advantage of being able to prove to clients that its designs can withstand the worst-possible conditions encountered under the sea. ▲

**This capability will provide Technip with the significant competitive advantage of being able to prove to clients that its designs can withstand worst-possible conditions.**

## Scaling Design Parameters

By **Mai Doan**, Senior Application Engineer, ANSYS, Inc.

Technip's customer wanted a rigorous study of every possible combination of parameters, and ANSYS DesignXplorer was up to that task. However, many companies employ DesignXplorer to study the design space with as few solved design points as possible. Advanced DOE and optimization algorithms within this tool enable users to choose combinations of parameters that extract the maximum amount of information with minimum resources. Response surfaces (also known as metamodels) interpolate between the solved design points. If, for example, peak loads or optimal designs are predicted between solved design points, these can easily be verified on an as-needed basis. Using automated refinement and adaptive optimization, DesignXplorer focuses solver resources in the areas of the design space that are most likely to yield valuable results.

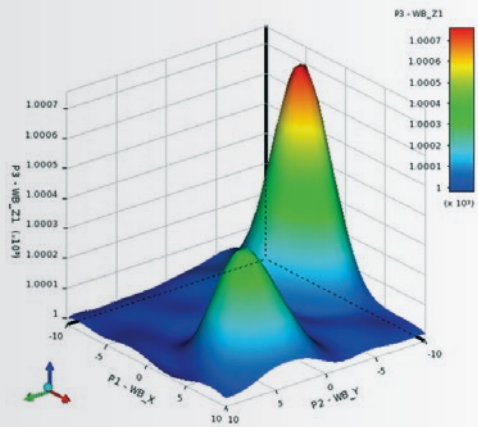

▲ Response surfaces show the relationships between design parameters and design performance.



# Powered by Innovation

Known for game-changing product innovations, Pratt & Whitney has relied on engineering simulation to fuel its design process for over 35 years. Al Brockett, former vice president of engineering module centers, discusses the role of robust design in delivering revolutionary new products with a high degree of confidence.

By ANSYS Advantage Staff



## Simulation has been critical to our efforts to lead our industry with entirely new classes of engine designs.

Brockett recently spoke with *ANSYS Advantage* about the changing role of simulation at the company, as well as Pratt & Whitney's increasing emphasis on robust design as a vehicle for launching its highly innovative products quickly, cost-effectively and confidently.

### As a longtime advocate of engineering simulation, how have you seen its application evolve at Pratt & Whitney?

Over the course of my career, I've seen simulation transform from simple numerical calculations to the incredibly complex, multiphysics problems we're solving today. Historically, Pratt & Whitney used complex simulations only for post-design analysis and verification. But today — thanks to advances in high-performance computing, process automation and software tools — we're leveraging simulation from the earliest stages of conceptual design through detailed design, through after-market service, to improve both speed and fidelity of our product development efforts and management of our products in service. Simulation has been critical to our efforts to lead our industry with entirely new classes of engine designs — and these represent a true step change over traditional architectures.

In the last 15 years, we've seen the speed and power of engineering simulation improve dramatically, along with the graphic capabilities and breadth of simulation software. Those tremendous advancements allow us to visualize problems in greater detail, consider multiple physics simultaneously, and conduct simulations that consider millions of degrees of freedom, all at a pace that matches the design cycle — something we couldn't have imagined at one time.

These improvements also allow us to respond much faster to our customers' increasing demands for new approaches to engine designs that answer their pressing needs for better fuel efficiency, lighter weight and reduced emissions. With fuel costs now accounting for 45 percent of an airline's operating expenses, this is a particular concern in our industry — and simulation continues to enable Pratt & Whitney to set the industry standard in maximizing fuel efficiency.

Since 1925, Pratt & Whitney has been a global leader in the design, manufacture and service of aircraft engines, auxiliary and ground power units, small turbojet propulsion products, and industrial gas turbines. From its first 410-horsepower, air-cooled Wasp engine to its award-winning PurePower® engine with patented Geared Turbofan™ technology, the company continues to revolutionize engine design to anticipate changing customer needs. Pratt & Whitney's large commercial engines power more than 25 percent of the world's mainline passenger fleet. The company also provides high-performance military engines to 29 armed forces around the world.

For over three decades, Pratt & Whitney has leveraged the power of engineering simulation to launch its groundbreaking innovations with the incredibly high degree of confidence required in the aerospace and defense industry. Al Brockett, who recently retired as vice president of engineering module centers, relied on the power of simulation throughout his long career at Pratt & Whitney. Under his direction, the company's global engineering team consistently redefined what is possible via engineering simulation — making Pratt & Whitney one of the world's most sophisticated users of simulation processes and tools.

## I've seen simulation transform from simple numerical calculations to the incredibly complex, multiphysics problems we're solving today.

### What role has engineering simulation played in some of your revolutionary product launches, like the new PurePower® engine?

The new products that we develop represent a multi-billion-dollar investment. Simulation helps to protect this investment by ensuring that our thousands of engineers and operations staff around the world are working efficiently, integrating functionality whenever possible, and minimizing costly rework.

In the case of the PurePower engine, we could not have developed this product, or sold it to customers, without incorporating engineering simulation. First, we needed simulation to design the Geared Turbofan technology that lies at the heart of this innovative new engine. (See sidebar “Gearing Up Performance.”)

Next, we leveraged simulation to demonstrate and prove the product to our customers around the world. This engine represents a technology shift — and delivers so many huge performance benefits — that our customers were naturally skeptical. To show them the Geared Turbofan™ engine in action, it would have been necessary to build a demonstration rig, run it for thousands of hours, and transport it around the world. And simulation gave us the capability to do exactly that, in the virtual realm. When we showed our simulation results to customers, alongside physical evidence of the engine’s reliability, they could not argue with the performance benefits.

As a result, we have sold five different variations of the PurePower engine to five different customers — and that leads me to the final way that simulation is helping us.

Simulation allows our engineers to move seamlessly among these five product platforms as we customize the PurePower engine design for Bombardier, Mitsubishi, Airbus, Irkut and Embraer. This is an unprecedented level of design activity at Pratt & Whitney. While we are developing five products simultaneously, they are based on a similar architecture. The teams can rapidly move from one product to another very seamlessly, and they can completely build off of one simulation to the next. We have been able to reduce the size of the overall development team needed to deliver these five product platforms, while maximizing the learning that takes place from one effort to the next.

#### Tell me about Pratt & Whitney’s internal robust design initiative, Design for Variation.

A common approach to product design is to utilize nominal geometry with some assumed variation in material properties. This method ignores the fact that parts/products are never completely produced at nominal geometry; it leads to conservatism in margins that are built in to explain the difference between predicted capability and actual capability. Controlling variation has become one of the keys to improving performance while also improving part yield and quality. Pratt & Whitney’s Design for Variation (DFV) program was created to help us improve our



COURTESY PRATT & WHITNEY.

products by quantifying and controlling variability, uncertainty and risk. Many companies, including ANSYS, refer to this as robust design.

DFV is really a paradigm shift that forces our engineers to statistically analyze a broad range of product geometries, boundary conditions and materials types. The program has changed from a special initiative focused on statistical training to a high-visibility strategic priority. (See sidebar “Robust Design at Pratt & Whitney.”)

The DFV concept is straightforward: If we assign a numerical value to our risks, we can manage them by making targeted changes in our designs, materials and processes that increase on-wing time for engines by managing the key sources of variation.

**Pratt & Whitney’s Design for Variation program was created to help us improve our products by quantifying and controlling variability, uncertainty and risk.**

## We can look at multiple physics very deeply, even assessing off-design conditions and the product system's reaction.

We examine thousands of design variations, each one slightly different, based on the probability that they will fail to meet operating requirements. We can then focus on a handful of factors that truly affect engine performance and reliability, and ignore those design points that are unimportant.

This obviously makes strategic sense, as it improves engine uptime, reduces component and maintenance costs, and protects passenger safety. But it's a massive undertaking to conduct this kind of parametric analysis.

Simulation makes DFV possible by running thousands of iterations quickly in an automated fashion. Our engineers can rapidly focus on those few design points and operating conditions that are truly critical. We can look at multiple physics very deeply, even assessing off-design conditions and the product system's reaction. The recent improvements in simulation technology are allowing us to move toward high-fidelity systems-level design, in which we will be able to isolate a dozen or so key points over an entire product system. That's exciting to consider.

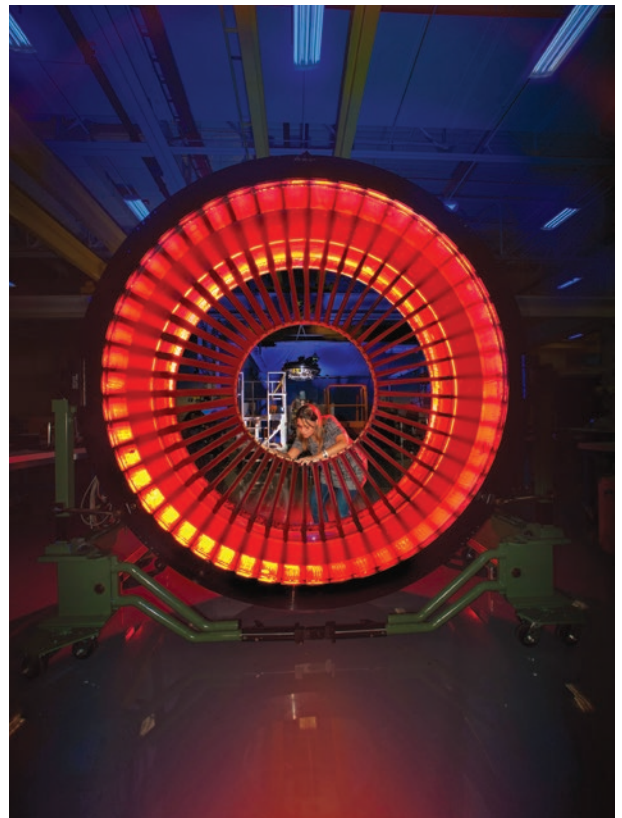

COURTESY PRATT & WHITNEY.

## Gearing Up Performances

Pratt & Whitney's PurePower® engine design represents one of the biggest advances in jet engines in the past 50 years. Pratt & Whitney engineers recognized that engine performance could be significantly improved if the fan and turbine that drives it could be operated at their own optimal speeds. To answer this challenge, Pratt & Whitney developed an innovative Geared Turbofan (GTF) engine design. Instead of connecting the fan directly to the low-pressure turbine via a shaft — as in conventional engine design — Pratt & Whitney engineers introduced a new reduction gearbox into the drive train.

In the resulting compact design, the bypass ratio has been improved from 5:1 to an impressive 12:1, and the low-pressure turbine develops more work in fewer stages. That means fewer airfoils, fewer life-limited parts and, ultimately, lower maintenance costs. The real-world performance results are also impressive:

- Over 15 percent improvement in fuel burn
- Up to 75 percent reduction in noise footprint
- Annual per-plane reduction in carbon emissions of over 3,000 metric tonnes

Already five major aircraft manufacturers have placed orders for the game-changing PurePower engine. Mass production is slated to begin later this year.



▲ PurePower engine COURTESY PRATT & WHITNEY.

### What advice would you give other engineering teams that want to increase their organization's focus on robust design?

I'm an advocate of what I call "design simulations": putting the right tools in the hands of designers to speed up the overall product development process. If your organization is serious about robust design, the first step is to make sure you have the right technology tools in place to manage large parametric simulations and drive rapid results.

Because robust design considers so many variables, any organization focused on this area is going to be running large simulations. An investment in high-performance computing resources is essential so that work can be accomplished and shared quickly. In just the last four years, Pratt & Whitney has quadrupled its computing capacity for a simple reason: We did not want computing power to be an obstacle to innovation and product integrity. For a small investment relative to the impact on our products, we are running large multiphysics simulations that support our DFV

initiative — which allows us to reduce the risk of design mistakes that could result in large downstream warranty costs.

While technology is important, education and training are also critical. I believe that the engineering community needs to place a greater emphasis on statistical analysis, which lies at the heart of robust design. Our engineering students today are not being adequately trained in this area, and I'd like to see that change. As performance demands in every industry become more complex — and cost pressures escalate — engineers need to become proficient at quantifying the impacts of different materials, part geometries and other factors on ultimate performance. They also need to understand and analyze for the interactions of multiple physical effects, since the systems we are developing are becoming increasingly complex.

Finally, at the organizational level, a key robust design concept is standardizing work processes, which has been a real focus at Pratt & Whitney for the last decade. When you are exchanging

## Robust Design at Pratt & Whitney

While robust design is an emerging concept for most companies, Pratt & Whitney began to focus on this idea as early as 1996. That year, as part of the company's internal quality program, every engineer was required to undergo training in statistical topics such as confidence intervals, probability distributions and regression modeling — and to understand how these concepts could help them solve common problems. Today, the company's Design for Variation effort has grown into a core competency, applied as a 10-step process that guides all engineering activities at Pratt & Whitney.

The company estimates that its component-level DFV initiatives have yielded a 64 percent to 88 percent return on investment by reducing design iterations, improving manufacturability, increasing reliability, improving on-time deliveries, and providing other performance benefits. As Pratt & Whitney focuses increasingly on the systems level, it estimates that it will realize a 40-times return on investment by achieving systems-level reliability goals much earlier in the development cycle. An ultimate benefit is shortening the overall development cycle.

### IDENTIFYING CRITICAL CONDITIONS THAT LIMIT PART LIFE

Many components of jet engines require cast materials with long lead times. This results in the need to design parts and commit to geometry long before thermal boundary conditions are measured, so these designs need to be robust across a range of potential thermal conditions.

The Mid-Turbine Frame (MTF), a component of Pratt & Whitney's revolutionary PurePower® engine located between the high- and low-pressure turbines, provides a fairing around the structural frame and bearing oil tubes. This frame carries the pressure loads on the part created by turning the air; however, the majority of these loads are driven by transient thermal gradients as the part heats from idle to takeoff conditions

and then cools again. The design requires various areas of the MTF to grow and shrink, as well as to smoothly distribute any thermal load generated so that stresses do not concentrate.

Life expectancy of an MTF airfoil is determined, in part, by the shape of its thermal profile, the magnitudes of local mechanical stresses and the inherent material capability. These are, in turn, determined by a number of factors: part-to-part variation (airfoil geometric variation within tolerances), engine-to-engine variation (thermal profiles), inherent material capability variation, and uncertainty in the lifing models. The combination of these types of uncertainty can cause wide variation in airfoil life.

In designing the MTF, Pratt & Whitney's goal was to find the nominal set of MTF features that would meet part life, weight and efficiency objectives while being robust with regard to all important sources of variability and uncertainty. The strategy was to make all models parametric, combine them into a single automated workflow, run a designed experiment over the model input space using the automated workflow with high-performance computing, and use the results to guide Pratt & Whitney engineers to a feasible/optimal region of the design space.

The parametric models included an NX® geometry model with automated meshing and ANSYS thermal and structural finite element models. A unique system called CCE (Collaborative Computing Environment) created a linked, distributed, automated workflow. All the building and execution of the analytical models resided with their owners and were linked together by scripts in a revision management application. The model input space covered the geometric design space, as well as the ranges of all variable features and uncertain parameters and boundary conditions.

The use of automated workflows with relatively large, multidisciplinary design spaces — as in the development of the MTF — requires efficient tools and techniques for solution visualization

work with engineers around the world, you need fast, reliable software tools as well as highly defined workflows and processes. We have created hundreds of internal courses in which we teach standard processes and methods that reinforce our commitment to quality and consistency.

#### How would you describe your relationship with ANSYS?

Since we are an advanced user of engineering simulation, we have collaborated with ANSYS on many projects and have given ANSYS a lot of product feedback. ANSYS software is a widely used commercial tool, which has led to a much broader implementation of DFV at Pratt & Whitney. Our younger engineers are familiar with ANSYS solutions, and they can easily fit the tools into our standard workflows. They like being exposed to multiple physics and seeing all the parts of a specific problem.

Probably the most important contribution that ANSYS has made is allowing Pratt & Whitney engineers to push the envelope of previous engine designs, all in a very-low-risk virtual

environment. We can see quickly what is possible, without making a huge investment in prototype construction and testing. Recently, we used multiphysics simulations — combining ANSYS Mechanical and ANSYS Fluent for example — to convince a major customer that they were making a design request that was not practical, because their modification would add significant weight to the engine. By showing them the real-world effects of their request via ANSYS simulations, which the customer also used, we avoided increasing complexity that we believe would have led to numerous issues. Without ANSYS software, some of these issues would not have been visible until installation. Today we are using ANSYS solutions in ways we never thought possible. ANSYS is definitely supporting our efforts to stay out in front of our industry as a leader and innovator. ▲

Manufacturing Variation



Temperature Variation

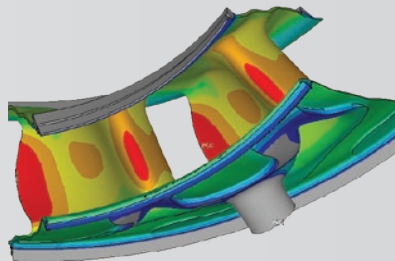

Stress Variation

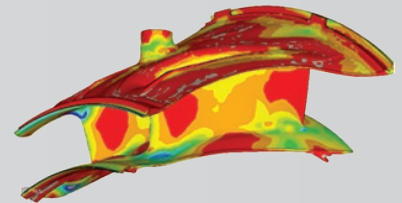

▲ In a search for a nominal design that is robust to variability and uncertainty, Pratt & Whitney created an automated workflow for its Mid-Turbine Frame that would ensure design robustness by considering a range of manufacturing, temperature and stress variations.

and evaluation. The goal is identifying the life-limiting locations and, at a more detailed level, detecting the parameters that are driving the part's life.

One of the tools for critical driver identification and insight into interaction between parameters is global variance-based sensitivity analysis. Global sensitivity analysis uses the results generated by executing the analysis workflow over a prescribed designed experiment. These same results are used to develop emulators for identification of feasible design regions. When needed, more detailed exploration can be executed for refinement of local design solutions.

The collection of automated workflows, variability and uncertainty analysis, and emulators allowed the Pratt & Whitney team to address its design challenges more quickly than by using traditional analysis strategies. For example, when aerodynamics refinements led to topological changes, the team used the established tools and process to efficiently adapt the toolset and continue the design activities. This enabled the team to design an A320 MTF that is robust with regard to uncertainty in thermal profiles — while exceeding life, weight and efficiency requirements and adhering to the design schedule.

# Sound Success

**JVC KENWOOD Corporation employs robust design practices to develop innovative automotive speaker technology.**

By Akira Shigeta, Loudspeaker Engineer, JVC KENWOOD Corporation, Tokyo, Japan

**T**oday's consumers demand smaller audio speakers with increasingly better fidelity. As a result, companies that supply these products must innovate to develop speakers that reliably deliver the best sound in a wide range of environments. Simulation can be valuable in meeting such robust design goals, in this case by employing parametric analysis of the voice coil.

JVC KENWOOD Corporation (JVCKENWOOD) serves a number of sectors: car electronics, professional systems, home and mobile electronics, and entertainment markets. The company's automobile speaker system design once was driven by expensive physical prototype building and testing, a time-consuming and costly process that limited the number of alternative designs that the R&D team could evaluate. JVCKENWOOD now uses ANSYS electromagnetic software to determine magnetic flux density distribution and other key parameters for proposed designs prior to prototyping. Engineers work with parameters and design points within ANSYS Workbench to quickly evaluate a large

number of potential designs and iterate to the optimal design. The end result: The company has substantially reduced prototyping cost, decreased time to market, improved product performance, and trimmed material costs.

**The company has been able to substantially reduce prototyping cost, decrease time to market, improve product performance, and trim material costs.**



## CAR SPEAKER DESIGN CHALLENGE

Audio speakers produce sound when the oscillating motion of a diaphragm causes corresponding oscillations in air pressure. The diaphragm motion is produced by a voice coil motor (VCM) device. This comprises a permanent magnet assembly containing an annular air gap, across which magnetic flux flows, and a wound coil that resides in the air gap. Electric current flowing in the coil produces Lorentz forces, causing the coil and the diaphragm to which it is connected to move.

Increasing magnetic flux in the gap of the magnetic circuit increases the loudspeaker's drive force. Although higher magnetic flux doesn't automatically mean better sound quality, higher magnetic flux and larger drive force provide a significant design advantage that enables engineers to deliver improved audio performance, greater sound volume, wider frequency response, and smaller and lighter designs.

In the past, JVC/KENWOOD engineers used hand calculations to determine magnetic flux density in the magnetic circuit's gap. However, these one-dimensional calculations were limited in accuracy because they did not take into account the system geometry. As a result, the company typically needed to make approximately 10 prototypes of each design to get insight into magnetic flux density distribution and other performance parameters. If the performance of the prototypes was not good enough, then it was necessary to spend extra time and money to rework the design and produce new prototypes.

## DESIGN ENGINEERS PERFORM SIMULATION

The ANSYS Workbench environment makes it easy to work with CAD geometry for electromagnetic (EM) simulation. ANSYS EM software is easy to use and provides results that can be simply viewed and understood. Design engineers can simulate speaker performance without having to involve analytical experts in the design process. ANSYS EM tools simulate low-frequency electric currents and electric fields in conductive and capacitive systems as well as magnetic fields resulting from current sources and permanent magnets. It features a complete range of automatic calculations for force, torque, inductance, Joule losses, field leakage, saturation and magnetic field strengths.

JVC/KENWOOD engineers begin the process by importing their CAD geometry into ANSYS DesignModeler. The parameters can be adjusted and the design updated, and any feature removal or simplification is maintained. They then perform low-frequency magnetic simulation with ANSYS Emag. Simulation helps to visualize performance of the magnetic circuit, particularly magnetic flux density distribution. Design of an automobile speaker is still more art than science — but simulation helps engineers to gain a much better understanding of how the concept design performs; it also helps guide the R&D team toward further improvements. Simulation often assists in finding breakthrough designs, concepts that even an expert designer might not imagine without it.

Engineers typically start by creating a few designs based on their experiences and then run simulations to determine performance. This type of study helps the engineer to move the design into the general area of what he or she is looking to achieve, but typically it does not approach optimal design. For example, with these early simulations, engineers might consider an inner magnet design with the magnet placed inside the voice coil versus an outer magnet design with the magnet outside the voice coil. They



▲ JVC/KENWOOD's car electronics group is well known for developing exceptional speakers. According to a review on autos.com, "KENWOOD eXcelon technology ... offers better sound quality based on the sound range as well as better quality parts and superb workmanship. A KENWOOD car speaker offers a great sound experience, but once you add in the speakers with the eXcelon technology, you will be amazed by the difference in range offered, and at what you hear in a song that did not seem to be there before."

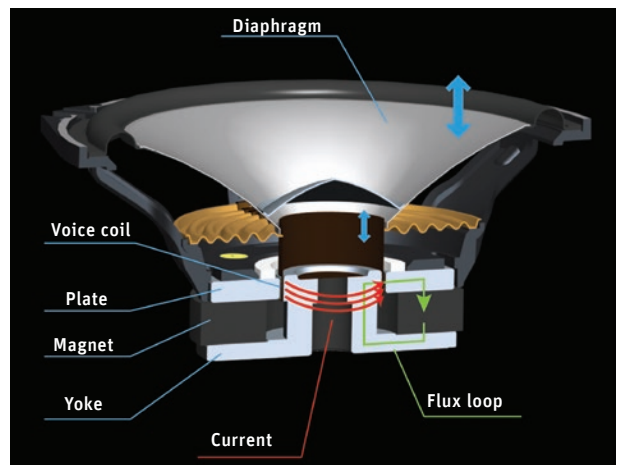

▲ Parts of the speaker

might consider using different magnet materials such as ferrite, aluminum–nickel–cobalt (alnico) or neodymium. Ferrite cannot be placed inside a voice coil, so it is suitable for only the outer magnet design. Alnico and neodymium typically work best inside the voice coil with a higher and narrower geometry.

## ITERATING TO AN OPTIMAL DESIGN

The next step is to optimize the magnet design, particularly by improving magnetic flux in the gap in the loudspeaker circuit. Engineers select design parameters that are most important, such as magnet thickness, internal diameter and external diameter. They set up these design parameters as design points in ANSYS Workbench and then run parametric analysis to study what-if scenarios. They define a series of values to explore in the table of design points. When the user clicks the Update All Design Points button, the first design point (with the first set of parameter values) is sent to the Workbench parameter manager. This drives changes to the model from CAD system to post-processing.

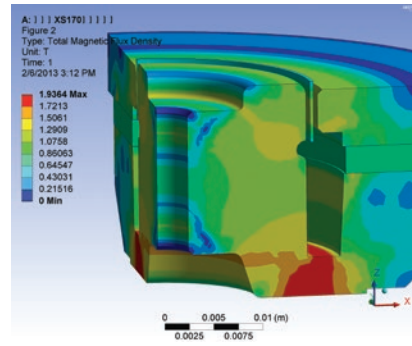
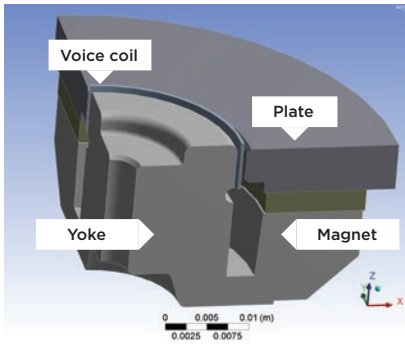

▲ Geometry of the magnetic circuit

▲ Simulation results show magnetic flux plotted on the magnetic circuit.

The new design point is simulated, and output results are passed to the design-point table where the data is stored. The process continues until all design points are solved, defining the design space that may later be optimized.

The next step is to optimize the magnetic circuit, which consists of the magnet, yoke and plate. Here the design parameters of interest are width, thickness and external parameters of the yoke and plate. The results provided by what-if analysis help engineers to quickly find the best design that satisfies all requirements.

Electromagnetic simulation and design optimization have made it possible for JVKENWOOD to substantially improve automobile speaker system performance. From a technical viewpoint, engineers can easily study new ideas, such as a completely new shape for a magnetic circuit,

without the time and cost involved in building prototypes. From a business perspective, engineering simulation helps to reduce prototypes, production costs and time to market. JVKENWOOD has significantly trimmed the number of prototypes produced for a typical project – from 10 in the past to today’s two or three. Time to market is now shorter by about a month, which is 10 percent of the total product development process. Magnetic flux density in the typical speaker has been increased by 5 percent without any additional costs. And finally, the amount of materials in the typical speaker has been reduced by up to 40 percent, which translates into lower material costs. ▲

*JVKENWOOD was supported in this work by ANSYS channel partner Cybernet Systems.*

## New Solution for Parametric Studies

With the most recent ANSYS release, a new licensing product is the ANSYS HPC Parametric Pack. This product amplifies the available licenses for individual applications (pre-processing, meshing, solve, HPC, post-processing), enabling simultaneous execution of multiple design points while consuming just one set of application licenses. See page 54 for more information.

– **Wim Slagter**, Lead Product Manager, ANSYS, Inc.

Outline of All Parameters				Table of Design Points									
ID	Parameter Name	Value	Unit	Name	P10 - d0...	P11...	P4 - Max	P5 - Max/2	P6 - Avg	P7 - X-Min	P8 - X-Max	P9 - Total	
1	PS170 (AS)			DP 5	2	64	42	1.6201	0.90216	0.75881	0.41314	0.90201	0.9013
2	PS170 (AS)			DP 10	2	64	44	1.5221	0.84156	0.70613	0.38491	0.84151	0.83914
3	PS170 (AS)			DP 15	2	62.5	40	1.4460	0.91941	0.77161	0.42048	0.91936	0.91562
4	PS170 (AS)			DP 20	2	62.5	38	1.7283	0.96971	0.81523	0.44629	0.96964	0.96705
5	PS170 (AS)			DP 25	2	62.5	42	1.8516	0.89997	0.73226	0.39247	0.8999	0.89771
6	PS170 (AS)			DP 30	2	60	40	1.5040	0.81254	0.68283	0.37413	0.81248	0.81044
7	PS170 (AS)			DP 35	2	64	40	1.7524	0.95928	0.80609	0.44037	0.95921	0.9565
8	PS170 (AS)			DP 1	2.2	64	40	1.7991	1.003	0.94289	0.46064	1.003	1
9	PS170 (AS)			DP 2	2.2	64	42	1.7069	0.9489	0.79623	0.43954	0.94884	0.94632
10	PS170 (AS)			DP 11	2.2	64	44	1.5959	0.89496	0.74365	0.40638	0.89491	0.89236
11	PS170 (AS)			DP 16	2.2	62.5	40	1.7275	0.96268	0.80884	0.44229	0.96263	0.95978
12	PS170 (AS)			DP 21	2.2	62.5	38	1.7887	1.0141	0.85203	0.46746	1.0141	1.011
13	PS170 (AS)			DP 26	2.2	62.5	42	1.6279	0.90206	0.76889	0.4133	0.90197	0.90009
14	PS170 (AS)			DP 21	2.2	60	40	1.3544	0.85276	0.71664	0.39283	0.85268	0.85053
15	PS170 (AS)			DP 2	2.5	64	40	1.3686	1.0111	0.89523	0.49694	1.011	1.011
16	PS170 (AS)			DP 7	2.5	64	42	1.804	1.006	0.84436	0.4581	1.006	1.0024
17	PS170 (AS)			DP 12	2.5	64	44	1.6991	0.9415	0.79154	0.43111	0.94146	0.93895
18	PS170 (AS)			DP 17	2.5	62.5	40	1.8219	1.0155	0.8936	0.47004	1.0154	1.0136
19	PS170 (AS)			DP 22	2.5	62.5	38	1.8908	1.0661	0.8956	0.49272	1.066	1.0633
20	PS170 (AS)			DP 27	2.5	62.5	42	1.7362	0.95744	0.8053	0.44041	0.95738	0.95497
21	PS170 (AS)			DP 32	2.5	60	40	1.6361	0.90789	0.76207	0.41687	0.90784	0.90518

▲ Engineers defined design parameters as design points to set up design optimization.

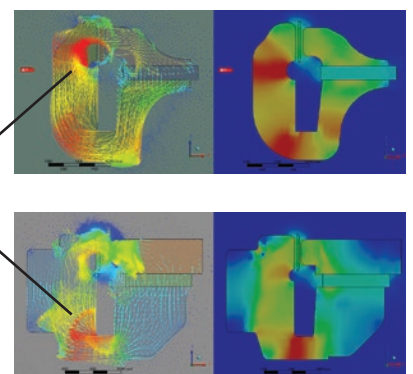

▲ Simulation is performed for each row of parameters on the optimization chart.

# Robust Simulations Demand Robust Processors.



Simulation-based design is changing the way companies prototype - Intel and ANSYS are driving those innovations.

Design simulation demands a professional-grade workstation. Intel® Xeon™ processor-based workstations give you the mega-tasking performance you need to instill design confidence, reduce product development cycles, and ultimately increase your manufacturing flexibility.

**Our highest-performing design for mega-tasking.**

The Intel® Xeon® processor E5-2600 product family-based expert workstation moves data faster for processor-intensive simulation, rendering, and ray tracing tasks.

Tackle your toughest ANSYS simulation tasks with the pure performance of Intel Xeon processors. Discover the difference of Intel Xeon processors at [intel.com/pureperformance](http://intel.com/pureperformance)



# A PERFECT FIT

Researchers develop an automated process for optimizing marine structural components.

By **Jouni Lehtinen**, Research & Development Engineer, MacGregor Dry Cargo, Kaarina, Finland, and **Sami Pajunen**, Associate Professor, and **Ossi Heinonen**, Researcher, Tampere University of Technology, Tampere, Finland

**N**early all marine structural components are custom designed for a specific application. It is also a fact that the highly competitive shipping market has no room for slack. Therefore, advanced ship builders and cargo system suppliers must optimize their structural designs to meet specific application needs. The bottom line: The structure's materials must be in the exact right place — where they best support the needs of the cargo system and enable efficient marine cargo transports. An optimized steel structure with no excess weight translates into optimized and flexible space for transported cargoes.

To address such issues accurately and efficiently, MacGregor Dry Cargo's engineering department and researchers at Tampere University of Technology developed an automated solution for optimizing marine structures; at the same time, the solution ensures that the structures are able to handle the required operating loads. This is done by means of a script that drives an ANSYS template file to perform a finite element analysis (FEA) on a series of design points. The results are used to construct a response surface model (RSM) of the design space. The RSM is reviewed to identify the most efficient design. This process also improves the reliability of the design by reducing the potential risk of design errors.

#### DEVELOPING NEW, EFFICIENT DESIGN METHODS

MacGregor offers integrated cargo flow solutions for maritime transportation and offshore industries. The competence center for MacGregor's Dry Cargo business line has a long history of cooperation with Tampere University of Technology, Finland's second-largest university in engineering sciences, for research and development of new design processes and tools.

In this particular marine component application, the team optimized the design to meet specific customer requirements. The cargo profile dictates the basic parameters of the ship's hull design. Within these constraints, the hull should be as light as possible in order to minimize material costs and also to keep the weight of the hull as low as possible. Any weight that is saved in the hull and cargo system design can be used for the benefit of the payload.

## With the automated optimization solution, MacGregor has a tool that optimizes the process more accurately and efficiently than before.

Using a standard design in this application — one that isn't optimized to the application — would have increased the amount of material used for the product with no additional value for the customer. Reusing previous designs with similar specifications also can be difficult, because many existing products were customized for project-specific requirements. Furthermore, the traditional approaches do not take advantage of technological advances in parametric design. Another solution for customer-specific optimization — such as simple design rules based on mathematical functions — does not take into account the detailed geometry of the structure, so designs created using this method are less than optimal. The most common method, conventional FEA, has the ability to accurately predict the performance of any single design. However, manual design optimization with FEA requires that a

skilled analyst individually study many different models. The high cost and long leadtimes of this process drive up engineering costs. Manual design optimization takes too long to use during the tendering stage, when customers come to MacGregor for a price quote and an initial design to be produced in short turnaround. Finally, assigning experienced analysts to repetitive work is often not the best use of resources.

An automated process to optimize marine structures for any application has to address the dimensions and loading of the structure, factors that may vary drastically from project to project. The main components of cargo handling equipment, in this case, are the top plate, longitudinal and transverse support beams, top plate stiffeners and bottom plate. Designers begin the process by creating a parametric mid-surface geometry model in SolidWorks® CAD software. The team uses symmetry



▲ A ship outfitted with a cargo handling system from MacGregor

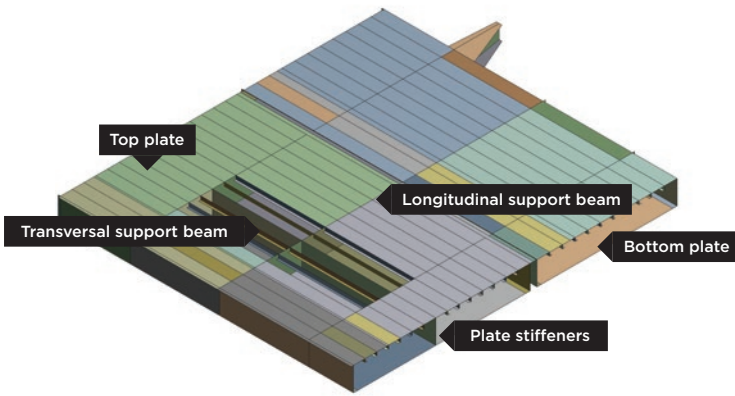

**This process improves design robustness by reducing the potential for design error.**

▲ Half of the structure with part of top plate removed to reveal structural members

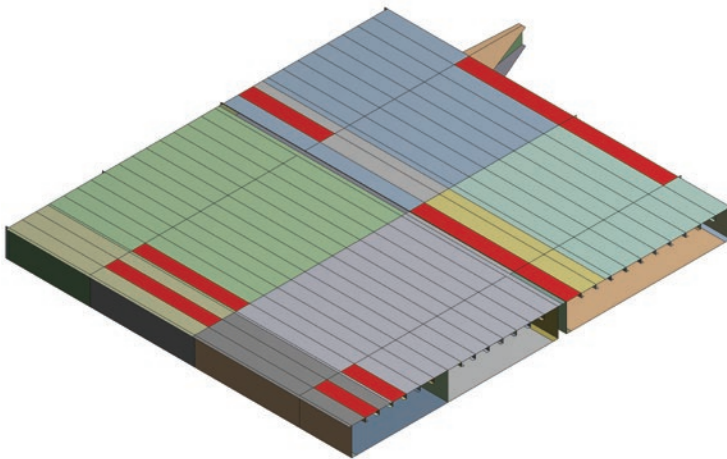

▲ The most critical areas of the top plate, marked in red, are checked for buckling during the optimization process.

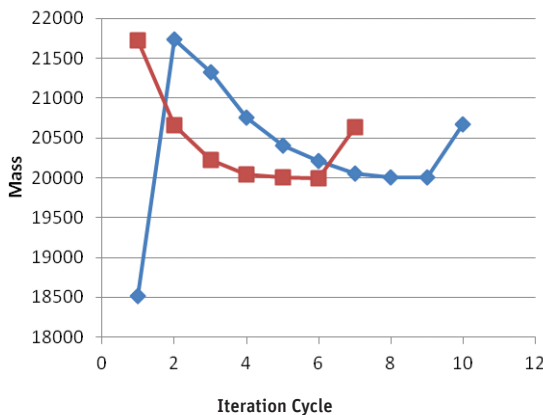

▲ Convergence of optimization sequences based on two different initial designs

to reduce the model to half of the structure. To employ this model, the customer provides the main dimensions of the structure during the tendering procedure, and the team enters these values as parameters into the surface model. Designers then parameterize the material thicknesses of the model as the key design variables to be optimized during the automated process.

**AUTOMATING FEA MODEL CREATION**

An ANSYS Workbench template file that contains ANSYS Parametric Design Language (APDL) commands automatically meshes the model using pre-defined meshing control settings. The team loads the structure with multiple uniform pressures as determined by the structural codes, and the structure is supported at designated points on the edges. The loads mainly cause compressive stress in the top plate, tensile stress in the bottom plate, and shear stresses on the support beams. The template file generates the load, support and material property definitions. The supports are defined with an APDL command that determines the displacement and rotation of specified nodes. Loads are defined using another APDL command to apply a surface force. The team uses the Named Selections feature to select the nodes and elements for applying the supports and loads. For example, the edges in the symmetry plane are defined as Named Selections and used for locating the supports. Named Selections are also used to define surfaces with the same material thicknesses in selection groups, so the

thickness of each element in selection groups can be defined with the APDL commands SECTYPE and SECDATA.

Researchers selected MATLAB® scripts to control the optimization. They used data from previous projects to select an initial design point that reduces the number of iterations required to reach the optimal solution. The scripts generate a D-optimal or Latin hypercube sampling (LHS) design of experiments (DOE) model centered on the initial design point and then drive ANSYS Workbench to create all of the models required to evaluate each run in the DOE model. The results are used to produce an RSM that approximates the complete design space based on the results of a relatively small number of FEA iterations.

### OPTIMIZING THE STRUCTURE

The scripts then scan the responses of each output variable in the RSM in a region of interest around the initial point using the simplex algorithm and determine the optimal design. Critical areas in each structural member group are defined as Named Selections so their stresses can be accessed with APDL post-processing commands. The team can easily access the mass of the structure through APDL commands. The optimization minimizes the mass of the structure with respect to constraints based on regulatory codes. The top plate is mostly under compressive and shear stress and, therefore, is constrained against buckling. The beam webs are almost entirely under shear stress and constrained against buckling. The stresses in the bottom plate are constrained so that the material will not yield. The design variables in the optimal design are used to generate another FEA iteration to confirm the RSM prediction.

The group tested the automated optimization method by applying it to a stiffened plate structure. The structure

is simply supported at support beam ends, and the boxes are connected with bar elements modeling the hinges that constrain the vertical displacements at specific points. The team loaded the structure uniformly on the top panels with a pressure of 45 kPa. The goal was to optimize 17 thickness design variables: eight top plates, four bottom plates, three transverse beams and two longitudinal beam webs. Constraints were derived from empirical knowledge captured from previous projects.

The team optimized the structure using two different initial configurations. The first initial configuration set all design variables at their minimum value as defined by the design rules: 7 mm for the bottom plate and 8 mm for the other parts. The other initial configuration set all variables equal to 9 mm. The optimization process ended when the relative change of mass from one iteration to the next was less than 1 percent. Both of the initial design points resulted in similar objective and constraint function convergence. The optimization process took about six hours using a desktop computer with a single core.

The researchers migrated the optimization process to a Techila Technologies Ltd. high-performance computing system cluster. The 18 design points used to create the RSM were run in parallel instead of sequentially, thus significantly reducing the time of each iterative optimization round.

This project demonstrates that design of marine structures can be quickly and inexpensively automated by constructing an RSM based on successive FEA analysis runs. The automated process optimizes the design in much less time than would be required by an analyst performing the same task manually. With this method, MacGregor can respond to a customer inquiry with a speed and accuracy that did not exist before, and with a design that is optimized for each specific application. ▲

*Development work has been supported by Finnish Metals and Engineering Competence Cluster (FIMECC).*

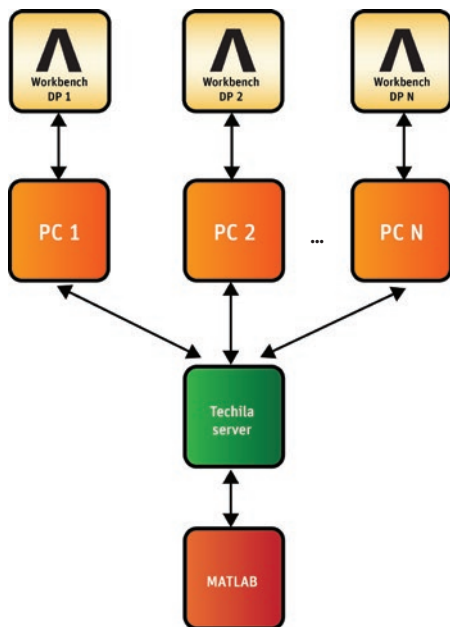

▲ Optimization process

**MacGregor can respond to a customer inquiry with a speed and accuracy that has not existed before, and with a design that has been optimized for each specific application.**

# Designing Robust Electronics Systems

Parametric simulation and high-performance computing ensure that engineers develop reliable electronic serial interconnects.

By **Guy Barnes**, Senior Application Engineer, and **Larry Williams**, Director of Product Management, ANSYS, Inc.

In the electronics industry, R&D teams often use extensive numerical simulation to explore device performance. Simulation provides an understanding of components and systems that laboratory tests are unable to deliver — in some cases, physical testing is not even considered as an investigative tool. It is possible to simulate an entire system early in the design cycle and to explore issues and parameter values to identify likely sources of system failure, long before they are locked into the design. Modern simulation methods take advantage of advanced computing hardware and novel numerical methods.

Engineers who design computer servers, storage devices, multimedia PCs,

entertainment systems and telecom systems are driving the industry trend to replace legacy shared parallel buses with high-speed, point-to-point electrical interconnects. Standard interfaces, such as XAUI, XFI, Serial ATA, PCI Express®, HDMI® and FB-DIMM, have emerged to provide greater throughput using serial signaling rates of 2.5 Gb/s to 10 Gb/s. While this trend has greatly reduced the number of traces and connections within the system, it has created new challenges for electronic system designers who must consider implementation with multiple connectors, transmission lines, vias, IC packaging and transceiver circuits. Very high speeds require the use of advanced, full-wave

electromagnetics simulation techniques to capture the interconnect's behavior.

## **SIMULATING THE PCI EXPRESS CHANNEL**

PCI Express (peripheral component interconnect express) is a high-speed serial bus standard used in virtually all PCs to connect the motherboard to expansion cards and add-in boards. This high-speed interface sends digital signals across a collection of individual components. Signals travel from the transmitter (TX) to the receiver (RX) by traversing the IC package, IC socket, PC board, PCI connector and board, and second IC package. Each component can disrupt the signal as it propagates from transmitter to



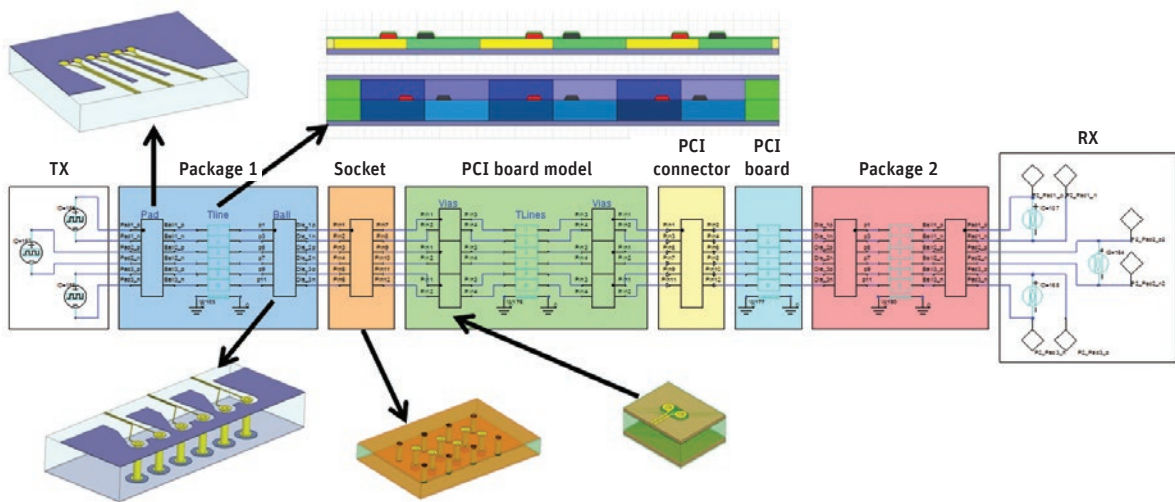

▲ PCI Express channel containing transmitter, BGA IC package, socket, printed circuit board, PCI connector and board, another IC package, and receiver

receiver. Engineers design components to minimize signal reflections and losses to achieve reliable communication. To do this, the engineer must understand how all of the components interact with one another within the full system.

Each component has its own set of tunable parameters. A transmission line on the motherboard, for example, has several parameters including trace width, thickness and spacing between traces; dielectric constant for the substrate; substrate thickness; and trace manufacturing defects, such as over- and under-etching. Another common component is a printed circuit board (PCB) via structure that allows circuit traces to traverse from one layer to another. Such a via structure with associated electric and magnetic fields can be simulated using ANSYS HFSS. The geometry has numerous parameters, including substrate thickness, dielectric

**It is important to understand how components interact with one another within the full system.** ▲

constant, routing configuration (input layer, output layer), via barrel thickness, pad diameter, anti-pad diameter and via stub length. Considering all of the components in the interconnect (as shown in the illustration), there could be 30 or more parameters that affect performance if all the possible variations are included. The engineer varies these parameters over a prescribed range to optimize the design for performance. Of course, each of these parameters has specific manufacturing tolerances, which is especially important considering that numerous vendors may be selected to supply materials and components. The challenge to the engineer, therefore, is to find a suitable design within the design space that is simultaneously robust to design variations and manufacturing tolerances.

It is easy to illustrate the vast solution space that can develop when each of the parameters have several values. For example, if each of 30 parameters has three values over some prescribed range, then the total number of possible combinations is  $3^{30}$ , which is more than 200 trillion! It isn't possible to measure all of the combinations. Even powerful simulation capabilities cannot provide complete coverage of such a vast solution space. To address this issue, a popular technique is to apply design of experiments (DOE)

**The challenge to the engineer is to find a suitable design within the design space that is simultaneously robust to design variations and manufacturing tolerances.** ▲

and response surface modeling. Response surface modeling enables the designer to model and consider all aspects of a high-speed channel design by fitting a statistical model to outputs of the simulation as a function of changes in input variables. A DOE table is used to select design points to solve to build the statistical model. Optimized conditions and worst-case scenarios are obtainable within the set of all possible design combinations.

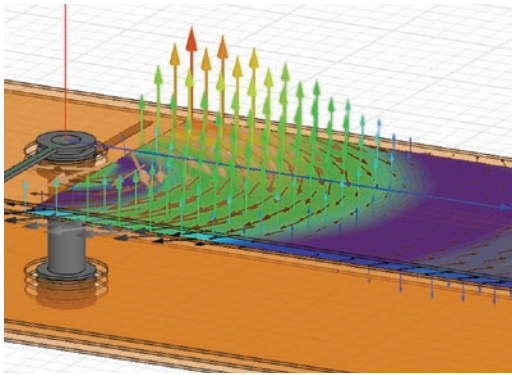

▲ Electric and magnetic fields surrounding PCB via structure as simulated by ANSYS HFSS

## Advanced numerical simulation coupled with high-performance computing allows engineers to simulate complete products and to fully explore the design space.

### SIMULATION PROCEDURE FOR DOE

To apply the DOE method to this high-speed interconnect example:

- Step 1:** Assemble the PCI Express channel using a systems-level simulation tool (ANSYS DesignerSI). Link this channel to electromagnetics models for all components (BGA package, connectors, printed circuit boards, etc.).
- Step 2:** Select variables for the DOE study and associated output observables. In this case, the outputs are selected to be eye-diagram height and width.
- Step 3:** Launch ANSYS DesignXplorer and set the variable range.
- Step 4:** Create a DOE table in DesignXplorer. The table is then passed to DesignerSI, and the full parametric simulation is performed. The distributed solve option (DSO) license accelerates simulations by running multiple parameters simultaneously on a compute cluster.
- Step 5:** Circuit simulation results from DesignerSI are passed back to DesignXplorer. DesignXplorer produces a statistical response surface model. Plots of sensitivities and six sigma behavior can be analyzed.

For this example, engineers used DesignXplorer to set up a DOE table requesting 2,001 independent simulations to be run in DesignerSI for the PCI Express channel. For each of these 2,001 simulations, parameter values were selected across a range as specified by the user, but the unique combinations of those parameters were set up automatically by DesignXplorer to obtain statistically independent results. To solve the scenarios required quickly, DSO with ANSYS Designer was employed. Eight parallel solves were performed at a time, taking advantage of all eight cores on a desktop server.

One useful graphical technique is to employ DesignerSI to produce an eye diagram of the signal as observed at the receiver. A broad sequence of digital signals is sent by the transmitter with switching events occurring to represent a digital one or zero, representing either a high- or low-voltage signal. Combining these simulated switching events one on top of another results in an eye diagram. An open eye with large eye height and width is an indication that a received signal can be detected reliably. A closed eye means that the signal swing and speed are insufficient for reliable detection.

The eye diagram represents the behavior of the PCI Express channel when a large number of bit sequences have been sent through the channel. It also shows the result of varying a subset of the 30 parameters over a collection of 2,001 trials, as set up in the DOE table. Some combinations of parameters result in a substantially closed eye, indicating a poor design point. A complete response surface for eye height and width can be generated,

Component	Associated Parameters (Numbered)
Package	Thickness, pad breakout, trace length, solder ball pitch, dielectric material (5)
Socket	Thickness, material properties, signal-to-ground ratio (3)
Board	Microstrip and stripline trace and spacing, etch factors, Cu roughness, dielectric material, via configuration (8)
Connector	Various vendor models, often only one or two options (1)
Second Board	Microstrip, stripline, etch factors, Cu roughness, dielectric material, via configurations (8)
Second Package	Thickness, pad breakout, trace length, solder ball pitch, dielectric material (5)

▲ Components in a typical PCI Express interconnect may have 30 parameters or more.

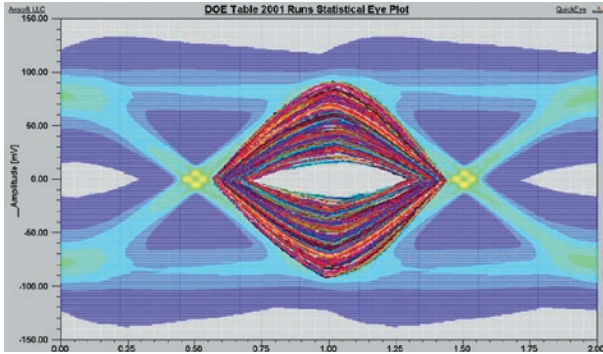

▲ Eye diagram resulting from large parametric sweep of example PCI Express channel. An eye diagram is used by engineers to determine if a digital signal can be received accurately. An open eye indicates that the interconnect has good performance.

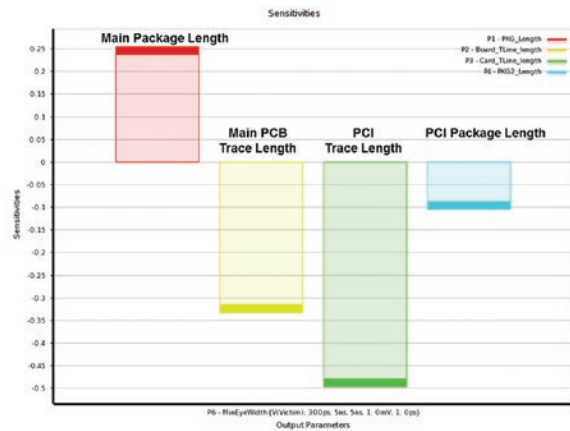

▲ DOE results for several significant parameters in PCI Express interconnect simulations. The PCI trace length on the peripheral card had the greatest negative impact on the eye opening, followed by the main PCB trace length.

providing the engineer with information about which parameters have the greatest positive or negative effect on interconnect performance. The engineer can obtain DOE results for several significant parameters in PCI Express interconnect simulations. The PCI trace length on the peripheral card had the greatest negative impact on the eye opening, followed by the main PCB trace length. Engineers can use this analysis to detect the most significant parameters on system performance. In this case, a more careful selection of the PCI peripheral card design and/or materials to reduce losses would improve this design.

### LEVERAGING SIMULATION-DRIVEN DESIGN

Advanced numerical simulation coupled with high-performance computing allows engineers to simulate complete products and to fully explore the design space, such as with high-speed serial interconnects. Simulation makes it possible to create a virtual prototype of the system so that design analysis,

parametric variations and optimization are performed before costly and time-consuming prototyping, lab tests and production. In the past, simulations could support only a single physics, a single user, a single component, and just a few design points. With today's modern high-performance computing hardware and software, it is possible to leverage a Simulation-Driven Product Development approach to include multiple physics, circuit and system simulations, and multi-user, multiscale simulations with parametric optimization and design exploration. ▲

## Reliable HPC Solutions for Electromagnetics Simulation

To enable robust design, HPC methods allow large electromagnetics studies to be distributed across a network of computers (cluster) to solve large 3-D volumetric problems, to perform material and geometry parametric sweeps, and to solve across frequency.

### DOMAIN DECOMPOSITION

The domain decomposition method (DDM) distributes a simulation across multiple, potentially networked cores to solve large, complex problems. DDM generates a continuous finite element mesh over the entire structure, then subdivides that mesh and uses a distributed-memory parallel technique to distribute the solution for each mesh subdomain to a network of processors. This substantially increases simulation capacity. Domain decomposition is highly scalable to large numbers of processors and takes advantage of multithreading within the mesh subdomains to reduce solution times for individual subdomains.

### SPECTRAL DOMAIN DECOMPOSITION

The spectral decomposition method (SDM) distributes the multiple frequency solution over networked compute cores to accelerate frequency sweeps. You can use this method in tandem with multithreading, as multithreading speeds up extraction of each individual frequency point, while spectral decomposition performs many frequency points in parallel. The spectral decomposition method is scalable to large numbers of cores, offering significant computational speed. SDM technology is available with ANSYS HFSS, HFSS-IE and Apache's Sentinel PSI.

### DISTRIBUTED SOLVE

The HFSS distributed solve option (DSO) accelerates sweeps of design variations by distributing design iterations across a network of processors. It works synergistically with multithreading to increase the execution speed of each design iteration. HFSS DSO offers a near-linear speedup over conventional design sweeps and is scalable to large numbers of cores.

# Robust Design for Integrated Circuits

A broad range of tools is required to meet reliability goals for robust electronic systems.

By Arvind Shanmugavel, Director of Applications Engineering, Apache Design

**D**esigning robust electronic systems requires a multi-step approach with emphasis on reliability simulations. High-performance integrated circuits (ICs) are the workhorses of today's electronics industry. Designers must pay special attention to verifying these ICs for several operating and stress conditions to deliver a robust electronic system. Simulations such as supply noise coupling, thermal impact on electromigration (EM), electromagnetic interference (EMI) and electrostatic discharge (ESD) are key aspects of IC reliability verification.

As consumer electronics and mobile industries attempt to integrate ICs with greater functionality and higher speeds

into smaller form factors, multiphysics simulation is key to capturing failure mechanisms. The automotive industry incorporates more and more electronic components in onboard safety and infotainment systems, mandating complex reliability verifications for ICs. No matter the application — from low-cost commodity ICs to high-lifetime and reliability ICs — there is a common theme of verifying complex failure mechanisms to meet product reliability goals.

## INDUSTRY TRANSFORMATION

The IC industry has undergone a dramatic transformation in the past decade. Integrating complex functional modules, such as processor cores, intellectual

property (IP) and high-speed I/O subsystems, has grown more common in IC designs. Performance, form factor and lower power are the driving forces behind IC integration in the mobile industry. On one hand, electronics product developers take a system-on-chip (SoC) design

**Multiphysics simulation is key to capturing failure mechanisms.**

approach to fulfill the need for complex functions and operating modes within a limited area of an IC. On the other hand, semiconductor foundries migrate to smaller technology nodes for tighter integration of transistors in a smaller area. The most radical change seen in this market segment is the move from bulk to multigate 3-D-FinFET transistors in advanced process nodes. FinFET transistors provide the unique advantage of lower leakage power with higher operating speeds, compared to planar transistors.

Another trend is integrating multiple ICs within the same package. The next decade will see further evolution: the integration of 3-D-ICs using through-silicon vias (TSVs), interposers and advanced packaging techniques. Lower power, higher bandwidth and form factor requirements are the main factors driving this transformation of ICs into 3-D-IC subsystems.

Just as the IC industry is embracing new transistor architectures, SoC integration and 3-D-IC packaging techniques, the simulation industry must keep up with complex verification needs. Failure analysis and reliability simulation needs to incorporate new multiphysics approaches for solving chip, package and system cosimulation challenges. Complex failure mechanisms must be simulated, including thermal failure, thermal-induced EM, EMI between ICs, and ESD in a multi-IC package.

## MARKET REQUIREMENTS

Reliability verification standards typically are dictated by the end use of an IC in a specific market. Consumer electronics and the mobile industry are by far the largest markets for ICs by volume. The smartphone sector integrates various high-end ICs, such as wireless modems, application processors, memory chips, GPS modules, CMOS image sensors and touch-screen controllers — all in an extremely small form factor. These IC components must perform reliably by themselves as well as in the context of the system. Typically, ICs inside a smartphone system must meet strict guidelines for lifetime reliability verification, ESD and EMI. Since smartphones are predominantly software application driven, different types of applications can dictate the reliability metric. For example, thermal reliability must be performed using

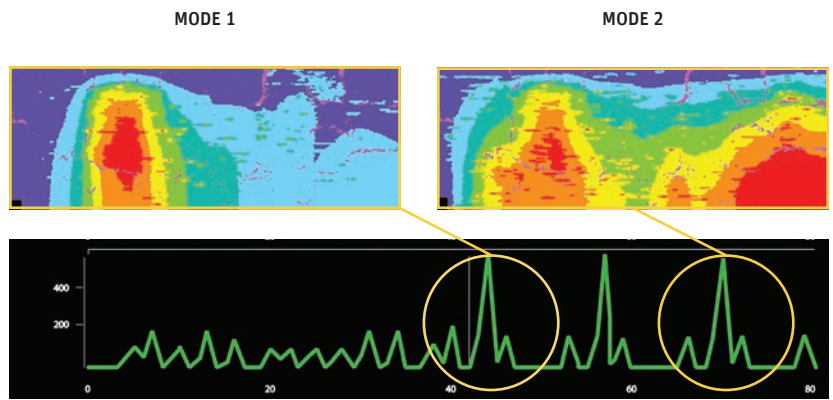

▲ Chip dynamic voltage drop based on two different operating modes

high activity modes with multiple wireless and GPS modules all operating at the same time. Conversely, lifetime reliability must be performed with the impact of the modes of operation through a three- to five-year lifetime.

In automotive, defense and aerospace industries, product reliability is highly important, often trumping the need for complex functionality. Mission-critical applications, such as safety systems in an automobile or fly-by-wire systems in aeronautics control, require electronic components that can tolerate extreme temperatures and constant electromagnetic interference, as well as operate throughout the system's entire lifespan. These systems have special reliability metrics for electronic components and may require meeting MIL-STD specifications. Typically, ESD and EMI standards are much higher than those for consumer-grade electronics for safety systems. EM checks are performed to meet a typical 10- to 15-year lifespan, compared to three to

seven years for consumer-grade electronics. Thermal standards for these ICs are typically checked between  $-55\text{ C}$  and  $+175\text{ C}$  to meet high-temperature operating lifetime (HTOL) metrics.

## RELIABILITY METRICS FOR ICs

### Electromigration and Thermal Reliability

EM is a well-known lifetime failure mechanism in the IC industry, represented by mean time to failure (MTTF), as defined by Black's equation [1]. Every IC designed today must be verified for EM failures for a specific product lifetime. Previously, EM checks were performed with worst-case operating conditions, typically including the highest activity for the device coupled with the worst-case operating temperature. However, with today's compressed IC design cycle, designers no longer have the luxury of designing for the worst-case scenario.

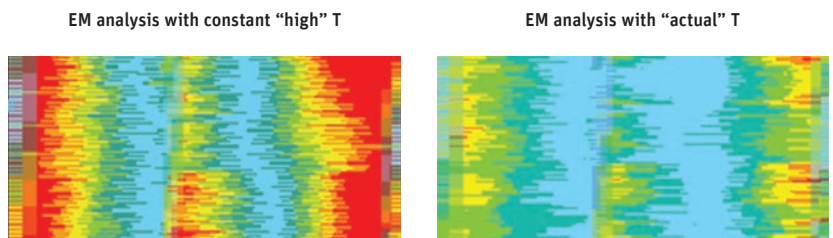

▲ Thermal feedback for electromigration analysis

Most smart ICs run some form of firmware or software, depending on the end use. The type of software application being run directly dictates the amount of activity that will be generated on the IC. Understanding the application-generated activity throughout the lifetime of the device is important for verifying EM failures. Consider the example of an application processor in a smartphone: The processor can transition between multiple operating modes such as video encoding, audio playback, GPS usage, call answer or sleep mode. Each application has a different activity factor generated on the IC. Each operating mode will use only a certain percentage of lifetime for the device. Understanding the activity factor for each mode of operation and the percentage of its use during the lifetime is important in performing EM simulations for the power, ground and signal nets. Designing the IC with an always-on high activity mode can lead to overdesigning the chip, which takes up valuable metallization resources that could be used elsewhere. To avoid this situation, using application-aware reliability modeling is a must for designing today's ICs.

The thermal impact on EM is another important aspect of reliability. The maximum EM limit for a metal wire in an IC decreases exponentially as temperature increases. Verifying EM for an

IC at the correct operating temperature can help to drastically reduce the number of true EM violations that must be addressed. Understanding the temperature gradient of an IC at a micron resolution is necessary for accurate reliability predictions. An IC's end application also needs to be considered during thermal-driven EM analysis. For mission-critical applications, worst-case operating temperatures are typically used for design sign-off. However, for mobile and consumer-grade electronics, an accurate spatial distribution of the temperature is generally used.

**Electrostatic Discharge**

ESD is the transfer of charge from one body to another, resulting in a large flow of current. An ESD event on an IC can inadvertently increase the voltage of the signal or power net beyond the device's breakdown voltage, ultimately rendering the IC useless. To protect operating devices from reaching high voltages, ESD protection devices are usually placed near I/O connectors, providing a low-impedance path for the ESD current to shunt the charge from reaching the operating devices. Utilizing a systematic simulation-based solution is necessary to carefully optimize these protection devices and verify proper ESD margins.

The ESD design margin is the voltage range above the normal operation of the IC but below the breakdown voltage of the specific process technology. This is typically the voltage range in which ESD protection devices operate to protect the IC from breakdown. As ICs move toward smaller technology nodes with lower breakdown voltage characteristics, the ESD design margin is drastically decreased, and the metal burnout characteristics are decreased as well. Re-using an ESD protection scheme designed in an earlier technology node can no longer be done in subsequent nodes. With die area at a premium and design margins shrinking, ESD schemes need to be designed with a systematic simulation-driven approach, placing protection devices at appropriate locations without overdesigning. Additionally, interconnect geometries must be verified against burnout during an ESD event by performing current density checks.

SoC integration with multiple cores and mixed-signal modules increases the complexity of ESD verification. Each core or module potentially can have its own power/ground network. Typically, an ESD pathway can be between any pair of power, ground or signal pin combinations. With the large number of power/ground domains in SoCs, protection devices must be placed between all possible combinations of power and ground nets to account for complex discharge pathways. Three-D-IC architectures pose a unique challenge in validating ESD. This type of IC has two or more dice in the same package module, so ESD pathway modeling needs to account for multi-die simulations when performing checks.

**Electromagnetic Interference**

EMI is caused when the electromagnetic field from one IC coupled with the metal geometries on the system interferes with the operation of a neighboring IC in the system. The failure mode of EMI is very difficult to model in electronic systems; however, electromagnetic radiation emitted by an IC coupled with the metal interconnects of the system can be modeled and simulated with a complete chip-package-system approach.

Using 3-D full-wave electromagnetic modeling tools for the package and board, along with proper current signatures for the

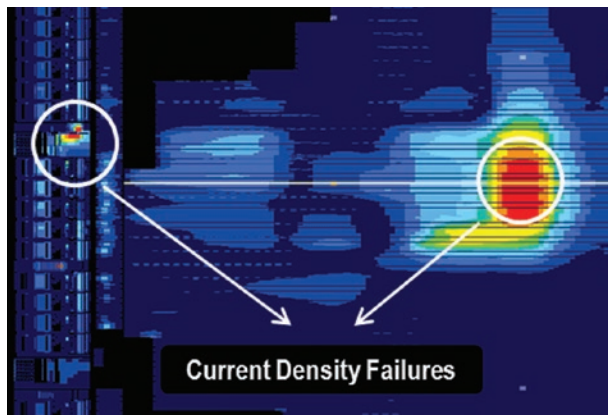

▲ Current density check during an ESD event. Highlighted areas in red indicate the points of metal failure.

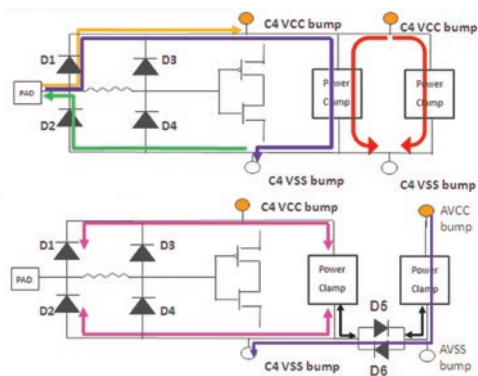

▲ Complex ESD pathway modeling for a typical IC. Every path highlighted should be checked against a resistance limit.

die, a user can accurately simulate the amount of near- and far-field radiation emitted by an IC subsystem. Typically, near- and far-field radiation patterns are simulated for multiple IC operating modes in the electronics system. EMI filter design and placement is usually done to filter out specific radiation spectrums and protect against electromagnetic coupling. Safety systems in automotive and aeronautics applications are commonly analyzed under varying load and ambient conditions for EMI before they are assembled in the system.

### FROM CHIP TO SYSTEM

Any electronic system consists of multiple ICs integrated on the same board or product. To ensure the robustness of a product, ICs need to be verified within the context of the electronic system. Additionally, the electronic system needs to be validated with the impact of the various ICs in their respective operating conditions. Chip-aware system design and system-aware chip design approaches are imperative due to complex failure mechanisms. A seamless model hand-off between IC and system designers is necessary to manage complex reliability simulations.

A chip-aware system design requires accurate IC models with a common reference point to be used in systems-level verifications. For example, a chip power model (CPM) of an IC with accurate impedance and current profiles is needed to verify proper electronic behavior of the system. Tools such as ANSYS SIwave and Sentinel-PSI can use a CPM model to perform system-level EMI verification. Similarly, a chip thermal model (CTM) of an IC is required to accurately predict thermal behavior of the system. Platforms such as Sentinel-TI and ANSYS Icepak can use a CTM to perform accurate thermal reliability simulations.

A robust system-aware chip design requires accurate modeling of the IC packages and circuit boards while performing die-level simulations. For example, an S-parameter model or electrical network of the package is needed to perform die-level transient voltage drop or ramp-up simulations. Tools such as ANSYS SIwave or Sentinel-PSI can create package models that can be used during a RedHawk transient simulation. Similarly, a die-thermal profile with micron resolution can be generated from Sentinel-TI to be used for accurate temperature-aware electromigration simulations of the die using RedHawk.

### SIMULATION AND IC RELIABILITY

Predicting lifetime and understanding failure mechanisms are important to any IC design process. Simulation tools must offer capabilities to understand the various operating modes, ambient conditions and system interactions with the IC to accurately predict failure mechanisms. Reliability verification tools also need to keep up with evolving process technology manufacturing and 3-D packaging techniques. A robust electronic system can be developed only by checking the impact of the IC on the system as well as the impact of the system on the IC. A combined chip-package-system cosimulation environment that can predict these complex failure mechanisms is necessary. Advanced reliability simulation techniques with multi-physics simulation are an integral part in realizing the promise of a robust electronic system. ▲

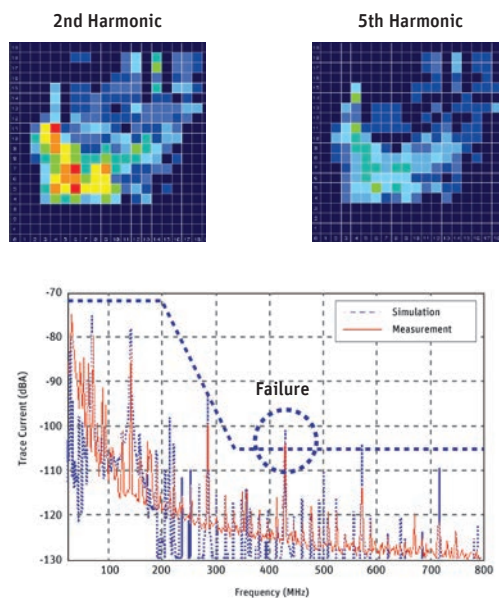

▲ Chip EMI map showing the 2nd and 5th harmonics. Failure highlighted when measurement exceeds the EMI limit.

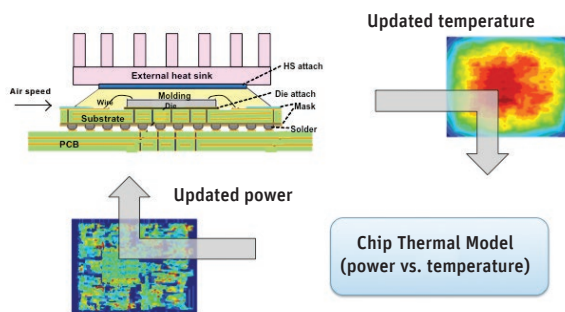

▲ IC power thermal loop using a CTM inside Sentinel-TI; convergence of power and thermal required for accurate IC temperatures

### References

- [1] Black, J.R. Electromigration Failure Modes in Aluminum Metallization for Semiconductor Devices. *Proc IEEE Lett*, **1969**, 57(9):1578–94.
- [2] Shanmugavel, A. Design for Reliability. Low Power High Performance Engineering Community, **2011**.
- [3] Shanmugavel, A. Reliability Verification for Smart ICs. Low Power High Performance Engineering Community, **2012**.
- [4] Shanmugavel, A. Design for Reliability – The Golden Age of Simulation-Driven Product Design. *EETimes*, **2012**.
- [5] Srinivasan, J. et al. The Impact of Technology Scaling on Lifetime Reliability. 2004 International Conference on Dependable Systems and Networks (DSN-04), **2004**.
- [6] Sarkar, A. Power Noise Analysis for Next-Generation ICs. Whitepaper, Apache Design Solutions, **2009**.

# POWER FOR A SUSTAINABLE FUTURE: REDUCING DOWNTIME

Simulation helps to improve productivity, performance and engineering innovation at a PTT gas separation plant.

By **Nattapong Maneemann**, Vice President, Gas Plant Facility; **Sunvaris Uywattana**, Senior Mechanical Engineer; and **PTT GSP Simulation Team**, PTT Public Company Limited, Rayong, Thailand, and **Sapha Pansanga**, CAD-IT Consultants PTE LTD, Thailand

Oil and gas companies around the world share a common objective: Reduce downtime while maintaining and growing production levels. To prevent operating losses of \$650,000 U.S. per day due to downtime, Gas Separation Plant (GSP) — an operation of PTT Public Company Limited (PTT) in Thailand — turned to simulation using ANSYS software.

PTT owns extensive submarine gas pipelines in the Gulf of Thailand and a network of liquefied petroleum gas (LPG) terminals throughout the country. Involved in electricity generation, petrochemical products, oil and gas exploration and production, and gasoline retailing businesses, PTT is the largest operator of gas separation plants in Thailand. GSP began operation in 1985; the maintenance department there chose ANSYS from the beginning as a supplier of proven tools to diagnose and rectify problems to improve production and save costs.

GSP has a computing cluster of 144 processors customized for ANSYS Fluent and ANSYS Mechanical software that allows the company to perform large simulations (up to 20 million cells) in a reasonable amount of time. High-performance computing with high-quality support from CAD-IT Consultants (an ANSYS service provider and distributor in Southeast Asia) allows the GSP team to quickly and accurately perform structural mechanics, fluid dynamics and fluid-structure interaction simulations to address a wide variety of operational issues. ANSYS software helps to support the team's design and



▲ PTT, the largest petroleum company in Thailand, is ranked 95th on the *FORTUNE* 500 list.  
PHOTO BY SAWANG SAPOONKHUM.

engineering decisions, and ANSYS HPC technology is a key enabler for solving high-fidelity simulations and increasing engineering productivity.

## BURNER OPTIMIZATION

A recent project simulated combustion in the burner of a waste heat recovery unit. The goal was to prevent overheating of a diffuser section that was causing days of downtime. Operating conditions and complexity of the geometry made it impossible to measure and obtain a detailed temperature profile inside the burner unit. Actual temperature measurements

were available only at some locations, making it very difficult to justify improvement options with empirical data. GSP decided to use Fluent to simulate four different new burner designs to analyze flow behavior and combustion characteristics.

Simulation for each design required approximately two weeks of computational time on 128 cores. This allowed engineers to determine temperature distribution in the existing diffuser and to compare those results to revised designs. After determining that the original design operated at around 1,050 C based on the measurements available, the team used



Fluent's combustion and radiation models to develop a new burner diffuser design that operates at a maximum temperature of approximately 950 C. The diffuser material (stainless steel grade 310 that has good resistance to oxidation in intermittent service up to 1,040 C) can withstand this temperature. Combining combustion with radiation models allowed engineers to ascertain the cause of the overheating, enhance their knowledge of flow behavior and temperature distribution inside the burner, and resolve the problem permanently by making minor changes to the diffuser wing geometry that resulted in changes in the flow pattern inside the burner. This alteration made a big difference in terms of maximum temperature in the system, and it allowed engineers to choose the appropriate material for the new operating conditions. The burner has a maintenance period of about four years; since implementation of this improvement, it has been running smoothly without any problems. The new design developed with simulation saves the company at least \$650,000 U.S. per day in costs that would have been incurred by lost productivity due to shutdown to solve unexpected problems or to check reliability of the improvement.

#### PIPING SYSTEMS STRESS AND VIBRATION

GSP operations include complex equipment — pipes, tanks, columns, support structures and heat exchangers — that must be correctly designed and maintained to ensure continuous operation 24 hours a day, seven days a week, with

**Without ANSYS Fluent, we would not have been able to understand the cause of failure, because it is extremely difficult to measure all parameters in the burner diffuser unit.**

— Sunvaris Uywattana,  
Senior Mechanical Engineer

# Simulation saved the company at least \$650,000 U.S. per day in costs that would have been incurred by shutdown.

minimum shutdown time. Engineers at GSP rely on simulation to fulfill specifications and maintain equipment reliability and structural integrity during operation. They use ANSYS structural mechanics software to examine and improve these structures as well as to ensure that the company's investment in these complex systems is secure.

For example, vibration issues in small branches of piping have been resolved using structural mechanics software. In these simulations, engineers perform stress analysis followed by fatigue life analysis. The geometry is set up in SolidWorks® and imported into ANSYS Mechanical to carry out nonlinear transient analysis. The team performed design improvements by adding some additional support elements then ran a stress analysis to verify the changes.

To ensure that temperature changes from elements added inside the pipe system had no external effect, the team performed thermal-stress analysis. The thermal load from CFD analysis was passed to ANSYS Mechanical, showing how the thermal load from the fluids influenced the structure of the new piping system design.

Engineering simulation helps the team to make certain that the system is not overengineered while ensuring that operating shutdowns are as short as possible. The team faces high safety-factor requirements that lead to increased piping support structures; these, in turn, constrain thermal expansion of the piping material. Simulation helps GSP to make the correct trade-offs in terms of engineering improvement and investment. Moreover, team members gain skill and knowledge through simulation, thereby enabling increased organizational know-how and encouraging sustained innovation. ▲

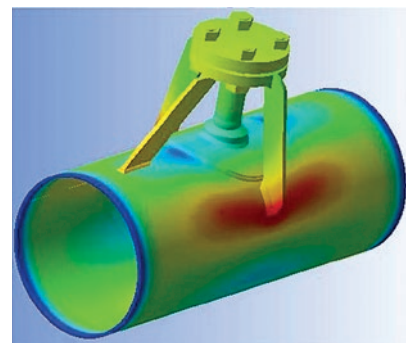
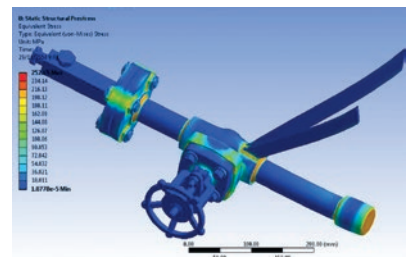

▲ Structural mechanics simulation predicted stress and deformation of pipes.

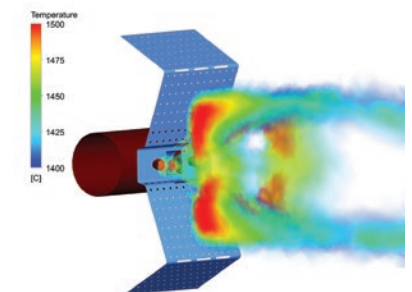

▲ Volume rendering of temperature around burner diffuser using ANSYS Fluent

# THE HEAT IS ON

Toshiba improves product reliability and decreases development time through electromagnetic–thermal–stress coupling.

By Toshihiro Tsujimura, Design and Development Center, Toshiba Corporation, Tokyo, Japan

To meet current time-to-market demands, designers must shorten design cycles and eliminate repetition of design steps, called “backtracking.” A critical area of product design is improving reliability and product lifetime under real-world conditions. Heat damage to components, subsystems and systems can reduce product longevity.

To address both of these challenges, Toshiba employs more and more computer-aided engineering analysis, with thermal analysis showing the sharpest increase in growth over the past six years.

Thermal analysis has always been important, but, due to new trends and design constraints, the latest designs experience more heat issues. For instance, decreasing product size to improve usability and decrease costs makes it more important to plan for and eliminate heat across all electronic product segments. In addition, to suppress noise or improve aesthetics, engineers tend to design fanless or enclosed structures. To provide higher-speed operation or increased functionality, today’s electronics products consequently consume more power. Finally, the use of multicore integrated circuits (ICs) can generate intense heat as well as require higher current on printed circuit boards.

All of these conditions have made electronic design more difficult, increasing the demand for robust, accurate thermal analysis as early in the design process as possible. Simultaneously, the need for accurate overall systems analysis during the simulation process has grown. Without a robust preliminary study, problems due to thermal stresses can be verified only in the post-production phase, such as during the power cycle test, which requires significant backtracking to adjust and rework designs.

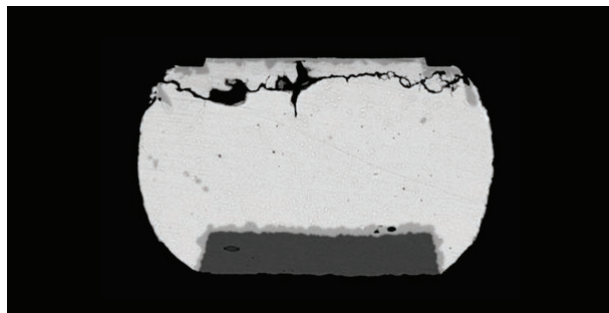

▲ Solder cracking due to thermal stresses

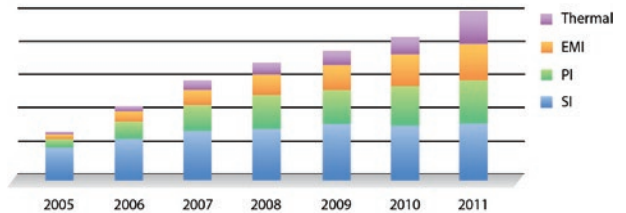

▲ In recent years, the engineering team at Toshiba has received more and more requests for thermal (as well as other) types of analysis.

What is needed is an optimized design process that uses a coupled electromagnetic–thermal–stress simulation in the early stages of design.

## IDENTIFYING THERMAL EFFECTS

To address onboard thermal issues, thermal analysis is necessary. Furthermore, engineers must couple electromagnetic and thermal analysis to perform an accurate study of heat in the concept and layout design phases. However, even if temperature specifications are met, other types of thermal issues may remain. For instance, rising temperatures can lead to thermal stresses that cause solder cracking, which prevents transmission of electromagnetic signals. Other thermal stresses can damage the product, shorten its life, and lead to product failure.

A circuit board often comprises several different materials, each of which has a specific expansion/contraction behavior. Thermal stresses occur when the length and volume of expansion/contraction of the various materials vary. To extend a product’s life, the R&D team must determine the point at which thermal stress occurs, and then optimize the design to avoid this condition.

An ideal concept and layout design process results in a robust design that does not experience any problems in terms of electricity, heat or stress. Specifically, the design should satisfy the electromagnetic and temperature specifications and be free of cracks. Toshiba’s goal was to conduct a study of design optimization methodology that included a set of coupled electromagnetic–thermal–stress simulations. If this study is successful, it will enable Toshiba to use this method early in the design cycle to help design for product integrity.

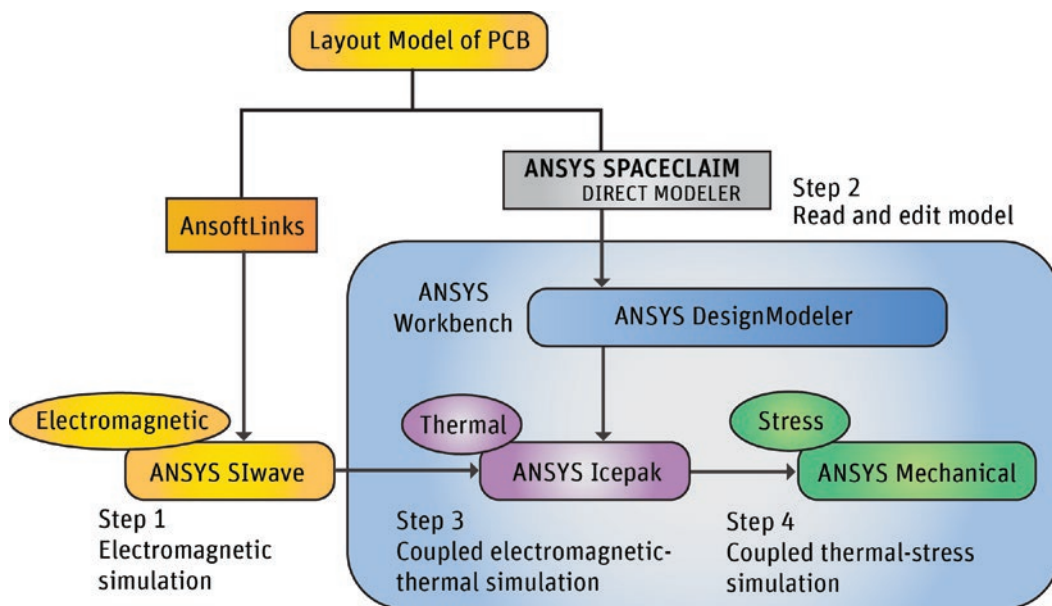

▲ Using a number of ANSYS products all within the ANSYS Workbench environment, it is possible to conduct a coupled electromagnetic–thermal–stress simulation to predict product lifetime.

## COUPLED SIMULATION

Coupled simulation recognizes that each condition, such as electricity or heat, mutually affects the other. So, instead of studying just the thermal effect caused by electric current, engineers must look into the effect of heating on the current flow in a design. For example, when electricity causes heat to be generated, this is a coupled phenomenon, and simulation of this is a coupled simulation. If the simulation also considers how the resulting heat affects the electricity, this is a two-way coupled simulation. Otherwise, it is a one-way coupled simulation.

Coupled simulation provides improved real-world accuracy, and it also increases simulation efficiency. In a traditional electromagnetic simulation, the engineer obtains a model, edits it, inputs the simulation conditions and conducts the simulation. Then, this entire process is repeated separately for a thermal simulation, and repeated again for a stress simulation. Consider the ideal scenario of a coupled simulation: A common model is obtained and edited in a single workflow,

which improves efficiency. In reality, however, engineers sometimes have to use different data for the various types of simulations and cannot always use a common model, which makes the coupled simulation process a bit more complex.

## ELECTROMAGNETIC-THERMAL-STRESS SIMULATION SETUP

Toshiba’s electromagnetic–thermal–stress simulation followed a specific workflow:

- Step 1:** Electromagnetic simulation
- Step 2:** Model creation
- Step 3:** Coupled electromagnetic–thermal simulation
- Step 4:** Coupled thermal–stress simulation

In step 1 (electromagnetic simulation), an ANF file is created from the PCB’s CAD data and a DC-IR analysis is conducted in ANSYS SIwave software, which evaluates the entire design, including coupling effects between traces, packages and boards. The current density and voltage drops are computed in the DC-IR analysis feature of SIwave to ensure that sufficient voltage is supplied to the ICs. Furthermore, the computed results of resistance and current distribution on the board are used to compute localized Joule heating.

In step 2 (model creation), ANSYS SpaceClaim Direct Modeler — which allows the user to move, stretch, add and remove elements with a mouse click —

**Toshiba’s need for accurate analysis of the overall system during the simulation process has grown.**

creates a 3-D model from the PCB's layout data. The model is sent to ANSYS DesignModeler to be simplified and edited before simulation.

For step 3, the ANSYS Workbench platform provides an integrated environment to guide the user through complex multiphysics analyses. Engineers conduct a coupled electromagnetic-thermal simulation that incorporates the data from the SIwave analysis (from step 1) and combines it with data from ANSYS Icepak, which is used for the thermal simulation. Specifically, the power loss information from the electromagnetic simulation is read into Icepak, and the board's plane is set as a heat source in the simulation. Since this is a thermal simulation, the ICs and enclosure are checked to see if they satisfy temperature specifications.

Finally, a coupled thermal-stress simulation is conducted in step 4 using ANSYS Mechanical software. The temperature distribution previously obtained in the thermal simulation is read into ANSYS Mechanical, and the stress results can be used to identify where mechanical failure may occur due to stress caused by heat.

### REAL-WORLD EXAMPLE

Consider the example of simulating a power supply board with a three-phase inverter with 20A of applied current to a single phase. A power supply like this often includes high current flow and high heat generation; therefore, problems of voltage drops, heat and stress can be expected.

The engineer verified the DC-IR drop in the electromagnetic simulation. The required data included the PCB layout data, value of current supplied, and minimum drive voltage for each IC (used to verify acceptable voltage drops). The simulation result showed that the narrow regions on the power plane had high current density, large resistance and, therefore, large voltage drop, suggesting that an ideal power plane would be wide and short. In fact, the simulation revealed that the narrower the plane, the greater the heat generated on the board.

Next, engineers created the model (step 2) and conducted a coupled electromagnetic-thermal simulation (step 3). ANSYS Icepak set the boundary conditions, convection and gravity. Engineers entered the IC's material properties and

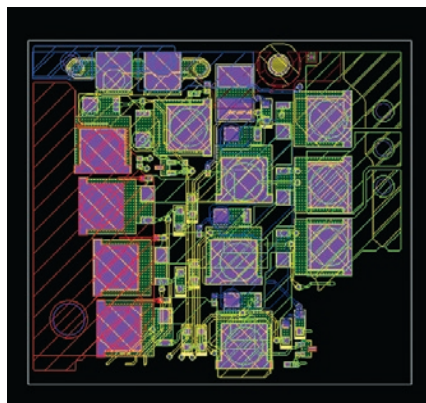
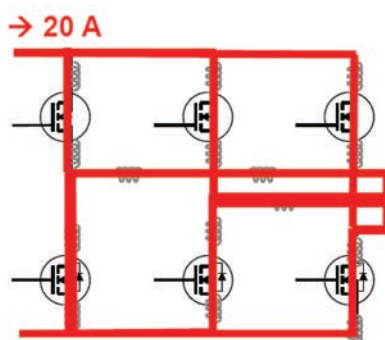

▲ Circuit schematic (top) and layout CAD (bottom) for a power supply circuit that involves high current and large heat generation

heat generation values, and imported the Joule heating values from ANSYS SIwave as heat sources for the thermal simulation.

Using this method, engineers could modify the layout model of the PCB and repeat the electromagnetic simulation if they found that the temperature specifications were not achieved in the simulation. Then, the updated PCB data could be directly imported into Icepak, allowing considerable

ease in the study for electromagnetic and thermal optimization.

Engineers compared the simulations with and without onboard heat generation (heat transfer from a copper trace to a plane in a PCB when power is supplied to the PCB component) to determine whether onboard heat generation was a concern. When compared with actual measurements, the simulation without onboard heat generation missed the measurements by 10.3 C at the maximum.

## A critical area of product design is improving reliability and product lifetime under real-world conditions.

# To accurately predict real-world performance of systems and subsystems, engineers must identify thermal effects and conduct coupled simulations.

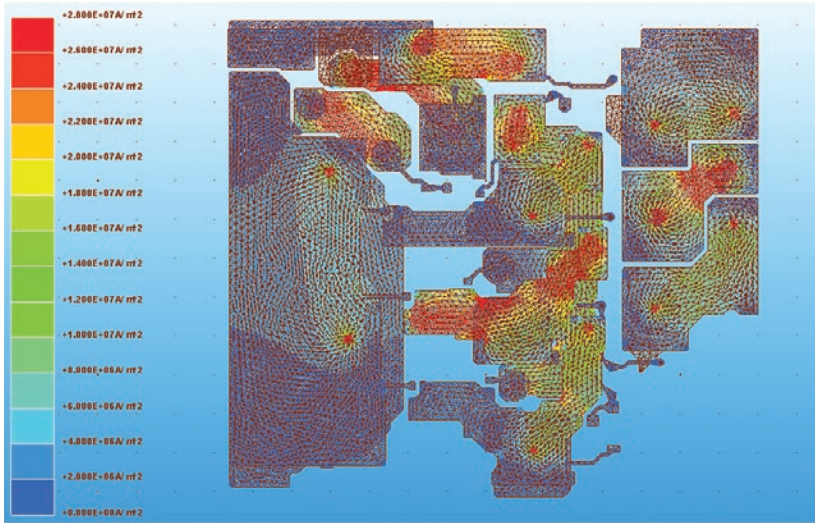

▲ Simulation results with SIwave for the circuit indicated that narrow regions on the power plane have high current density and large resistance and, therefore, a large voltage drop.

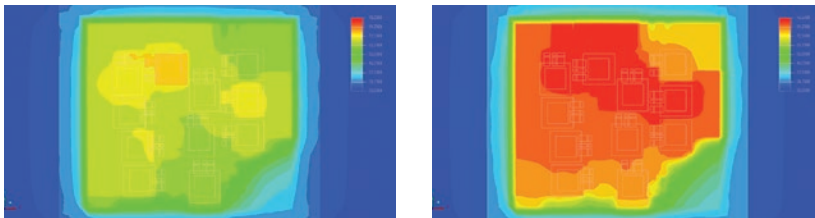

▲ By including onboard heat generation (right) by coupling with the electromagnetic simulation temperature from SIwave, temperature values as well as their distribution changed in ANSYS Icepak.

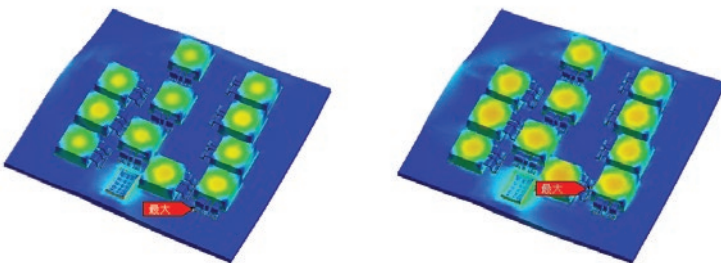

▲ The inclusion of temperature distribution from Icepak thermal simulation affected the results of a stress simulation in ANSYS Mechanical. Increased stress and a change in the position of maximum stress are indicated in the simulation that included coupling, on the right.

By including onboard heat generation in the simulation, the error could be reduced to a maximum of 2.3 C. This analysis confirmed that including onboard heat generation improved accuracy, and this result was confirmed by comparison with measurements.

Finally, engineers coupled thermal and stress simulation. ANSYS Workbench read the model from DesignModeler into ANSYS Mechanical and also read the temperature distribution data from Icepak. Engineers input mechanical properties, set constraint conditions for the stress simulation, generated a mesh for the structural simulation, imported thermal simulation results, and conducted a thermal–stress simulation. In this example, the thermal simulation determined that the maximum stress for this design would occur between the IC pins and the board. This made it possible to identify the most problematic region in terms of stress and to optimize the design to address these issues by repeating and iterating electromagnetic and thermal simulation steps within ANSYS Workbench, as needed.

This study confirmed that to accurately predict real-world performance of systems and subsystems, engineers must conduct coupled simulations to identify thermal effects. Using coupled simulation, Toshiba engineers increased the accuracy of temperature predictions and determined stress effects on a power supply board. Employing coupled simulation early in the design process can lead to more reliable products with longer life. ▲

## Employing coupled simulation early in the design process can lead to more reliable products with longer life.

# FORMULA FOR RACING SUCCESS

Students apply robust design principles to develop a highly competitive race car.

By **Philipp Epple**, Professor, and **Peter Neugebauer**, University of Applied Sciences Coburg, Faculty of Mechanical Engineering and Automotive Technology, Coburg, Germany



▲ C-12 Puma from CAT Racing

**F**ormula Student Germany (FSG) is an international race car design competition for students at universities of applied sciences and technical universities. The winning team is not the one that produces the fastest racing car, but the group that achieves the highest overall score in design, racing performance, business planning and marketing.

Since 2007, students of the University of Applied Sciences Coburg (UAS Coburg) have participated in this competition as part of the Coburg Automobile Team (CAT). Members of different faculties, including mechanical engineering and automotive technology, business administration, and civil engineering and design, take part. During the four races of the 2012 championship, CAT Racing twice achieved second place. Group members accomplished this success with hard work, discipline and outstanding technical equipment.



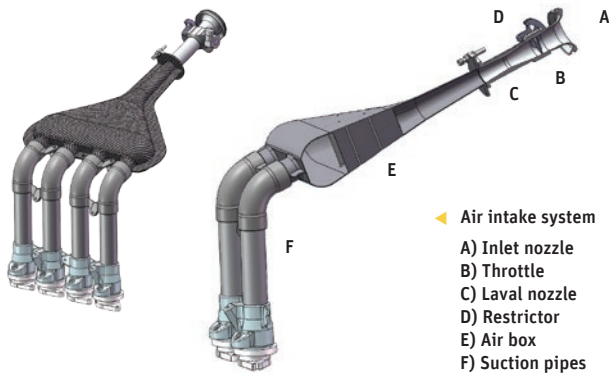

◀ Air intake system  
 A) Inlet nozzle  
 B) Throttle  
 C) Laval nozzle  
 D) Restrictor  
 E) Air box  
 F) Suction pipes



Race car aerodynamics, and aerodynamics in general, takes two forms: external and internal flows. External aerodynamics applies to the external shape of the race car; engineers study it to determine the down force on the chassis that will deliver ideal driving dynamics by minimizing aerodynamic drag. The aerodynamics of the car's internal components is just as important. For example, predicting aerodynamics of the air intake system is crucial to optimizing car performance as speed changes. The air intake system consists of an inlet nozzle, throttle, Laval nozzle-shaped restrictor, air box and cylinder suction pipes.

### AIR INTAKE DESIGN

The team from UAS Coburg improved the car's air intake system using ANSYS CFD within the parametric ANSYS Workbench environment. FSG regulations limit the minimum diameter of the restrictor to 20 mm, which regulates the maximum intake mass flow rate. The air box, downstream of the restrictor, directly influences the amount of fresh air reaching the cylinders. An air box that is too large causes the motor to react too slowly to the accelerator and, in combination with short suction pipes, triggers the engine to develop sufficient torque only at high rotation speeds. An air box that is too small behaves in the opposite



▲ Formula Student Germany CAT Racing team from UAS Coburg



manner. Therefore, the team needs to carefully design the air box and match it with the suction pipe lengths to optimize torque over the entire range of operating speeds. In earlier CAT Racing cars, the air box was designed mainly based on ease of construction; in 2012, ANSYS Workbench was employed to develop a true aerodynamic design. As a result, the 2012 race car model, the C-12 Puma, delivers the correct torque to the driver at the right time (that is, at the proper speed). This optimization allowed the team to win two second-place finishes.

The faculty of Mechanical Engineering and Automotive Technology at UAS Coburg has access to modern technical equipment, including an engine test rig, which the team used to test the ANSYS Workbench design before road testing. Facilities also include an advanced computer lab, where students employ ANSYS software to obtain the optimal design.

The team developed the air intake system in three steps:

- Students computed and analytically dimensioned the system based on equations of theoretical gas dynamics using an Excel® design tool.
- The team implemented the design in CAD using SolidWorks® to determine the flow domains for CFD simulation.
- UAS Coburg performed optimization within the ANSYS Workbench environment. The team generated a parameterized CAD model and transferred the model to ANSYS Workbench using the CAD interface for SolidWorks. CAT Racing then generated a table of design points within Workbench. At each new design point, the data was transferred through the ANSYS CAD interface to SolidWorks, where a new geometry was generated. This new geometry was then returned automatically to Workbench, where a new grid was generated, and the CFD solver started automatically. This process was repeated until all design points were processed.

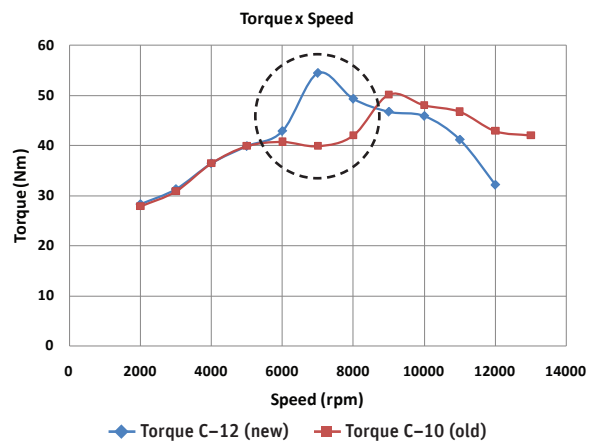

▲ The C-12 Puma generated the correct amount of torque at the right speed.



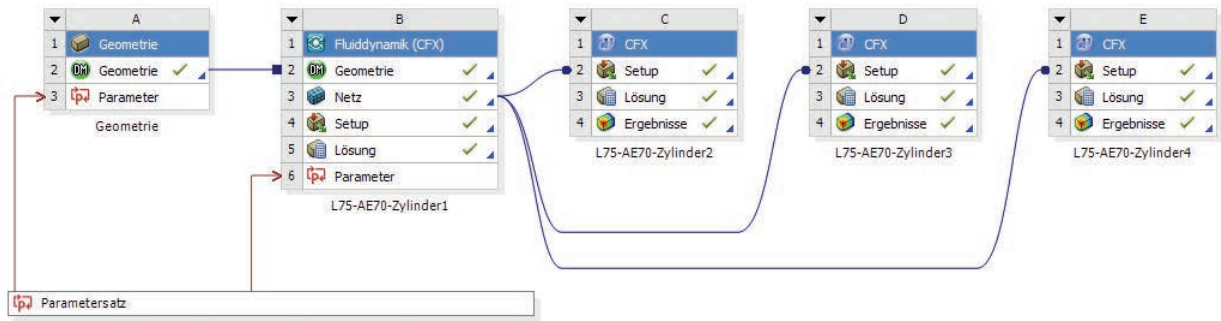

▲ ANSYS Workbench workflow

### ANSYS WORKBENCH PARAMETERIZED WORKFLOW

The optimization procedure in ANSYS Workbench is very effective and user friendly, employing a simple workflow. Geometry is easily imported into ANSYS DesignModeler within Workbench using the ANSYS CAD interface for SolidWorks. Still within Workbench, the mesh is generated from this geometry using ANSYS meshing. The grid parameters are set once, and then the grid can be generated automatically in the background for all configurations of the geometry without reopening the meshing tool. For the air intake, the team included four configurations (corresponding to each of the four cylinders) in the workflow, and each design was run for all of these configurations. Workbench auto-detected these configurations and ran them sequentially.

Once the CFD solver (ANSYS CFX) finished running all four configurations, the next parameter in the table of design points was sent back to SolidWorks. Using this parameter, SolidWorks generated the next geometry set, which was then passed to Workbench, and the solution process was reinitiated.

Using this method, the team investigated two- and three-dimensional models of the air intake system. The advantage of this procedure is that 2-D models are computed rapidly so that fundamental alternatives can be explored and the design quickly altered – for example, to maximize mass flow rate through the system. CAT Racing then developed 3-D models for the 2-D geometries that gave the best performance, and conducted 3-D CFD simulations. Again, the CAD interface and table of design points generated CAD models and grids, and provided parametric

solutions within the Workbench environment. High-performance computing was conducted on some of the 3-D cases to increase solution speed.

In the original air box, the CFD simulation showed that the flow failed to reach the cylinder in a direct path. The central separation caused by the design of this original box based on structural requirements actually obstructed the flow. To solve this problem, the UAS Coburg team added guide vanes to the air box. With an automatic optimization loop implemented in ANSYS Workbench, the team optimized the number of guide vanes, their thicknesses, the opening angle of

**The optimization procedure in ANSYS Workbench is very effective and user friendly, employing a simple workflow.** ▶

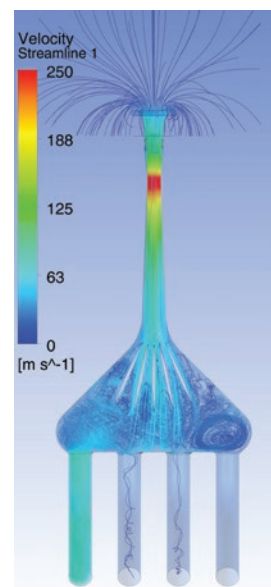
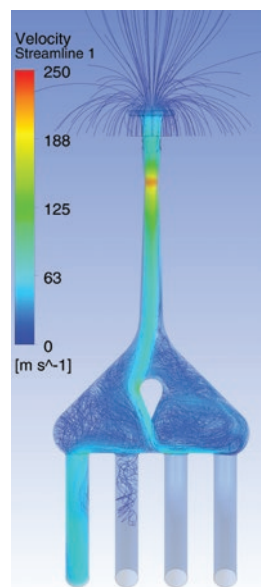

▲ Old C-10 (left) and new C-12 (right) air intake system. In the original air box, the flow does not reach the cylinder in a direct path. The addition of guide vanes in the new system provides better intake and more uniform distribution of air flow.



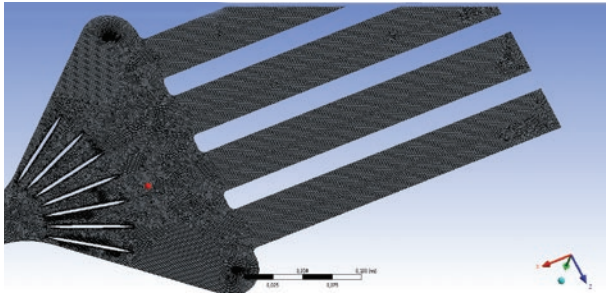

▲ Grid generation with ANSYS meshing

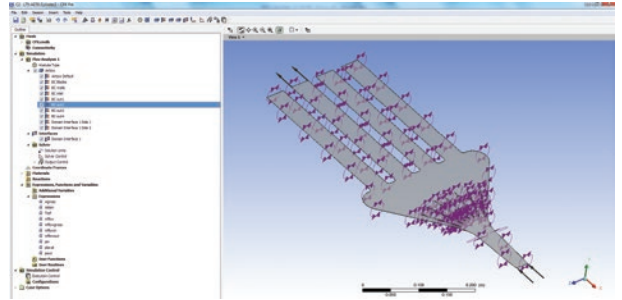

▲ One of the four setups in ANSYS Workbench, with the second suction pipe in operation

the air box and other parameters. This system of guide vanes in the air box diverted the flow into the corresponding open cylinder with negligible flow separation. Losses in the system were reduced, and the mass flow rate through the restrictor was increased. The structural stability of the air box also was improved. In the new system, the air box flow distribution is more uniform.

### ENGINEERING BY THE NUMBERS

The requirements for simulation post-processing go beyond producing a series of pretty pictures. The team needed to extract quantitative information, so the CFD result files were further post-processed using power syntax within CFD-Post. This feature can be integrated with the well known and powerful programming language PERL to access complex post-processing functionality.

Using PERL and CFD-Post power syntax, the faculty of the Mechanical Engineering and Automotive Technology

department wrote complex post-processing scripts to precisely extract relevant data from the CFD result files and write the calculations to an Excel file. These results then were displayed and analyzed in charts. Using this method, it was possible to analyze and compile a huge amount of simulation data in a clear and concise way. The team analyzed total pressure, static pressure, Mach number, entropy, enthalpy and other data throughout the system. Based on this information, CAT Racing was able to analyze the system objectively and gain the knowledge required to effectively improve the design of the air intake system.

Additional aspects of internal and external aerodynamics of the Formula student race car are currently being analyzed at UAS Coburg. Combined with a sound knowledge of theoretical aerodynamics and a modern test facility, CFD simulation using ANSYS Workbench continues to be a key technology in the car's aerodynamic development. ▲

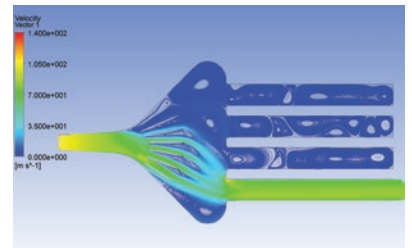
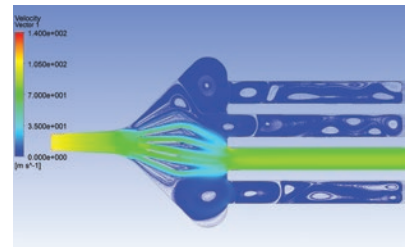
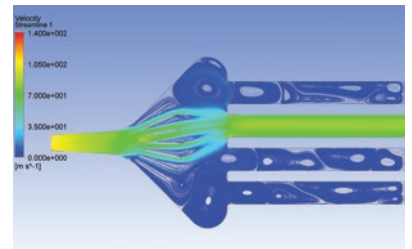
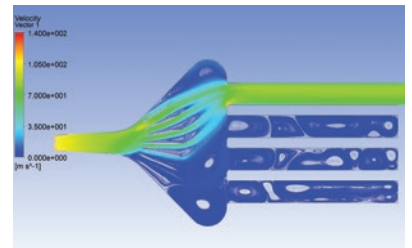

▲ Two-D model of the new air box showing flow through cylinders



▲ Air box CAD model (left), 3-D CFD simulation (center), air box installed in racing car (right)

# CARDIOVASCULAR ENGINEERING

As engineering and medicine converge, researchers are making gains in understanding and treating causes of cardiovascular disease.

By Santhosh Seshadhri, Technical Services Engineer, ANSYS, Inc.

**C**ardiovascular diseases are the main cause of illness and premature death in the European Union (EU). This class of diseases that affect the heart and blood vessels accounts for approximately 40 percent of deaths, with a combined direct/indirect economic cost of approximately €196 billion per year. National health systems are tasked with providing health services to an increasingly aging population under tight fiscal constraints with the additional challenge of providing personalized healthcare, which tailors treatment to the individual patient. Because predictive models of cardiovascular disease and device intervention are expected to yield substantial health and economic benefits, research in this area has received increasing attention and funding in recent years.

ANSYS is playing an integral role in cardiovascular research, collaborating in EU projects @neurIST, GEMSS, COPHIT, BloodSim, BREIN and RT3S. MeDDiCA (Medical Devices Design in Cardiovascular Applications) is one such multidisciplinary and multi-center project funded by the European Community's Seventh Framework Programme. This Marie Curie Initial Training Network (dedicated to making research careers more attractive to young people) involves a number of universities across Europe that simulate cardiovascular problems of interest with the support of ANSYS engineering tools. A key goal of the MeDDiCA network is nurturing early-stage Ph.D.'s and post-doctoral researchers in a variety of disciplines to help them develop a broad range of scientific and individual skills.

State-of-the-art simulations of the cardiovascular system are based on the

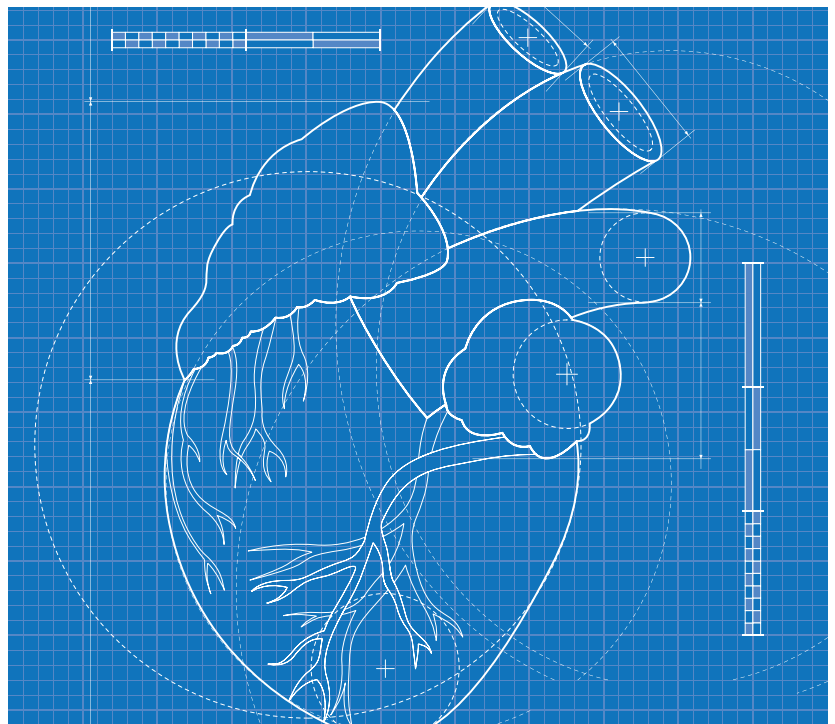

integration of observations, theories and predictions across a range of temporal and spatial scales. Interactions can be investigated *in silico* (via computer) to bring new insight about phenomena observed *in vitro* (in an artificial environment, such as a test tube) and *in vivo* (via medical testing of a living organism) and to assist in the formulation and validation of new hypotheses. The nature of such research is highly multidisciplinary, combining aspects of physics, chemistry, mathematics, engineering, computer science, biology and medicine. The following examples of cardiovascular research as part of the MeDDiCA project focus on the heart and the blood vessels.

**Cardiovascular diseases account for approximately 40 percent of deaths in the European Union.**

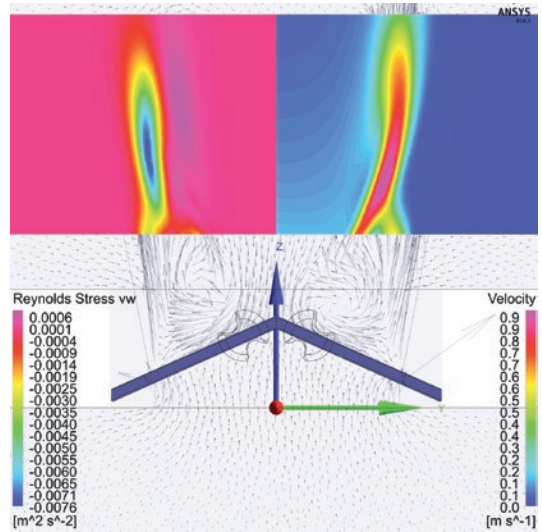
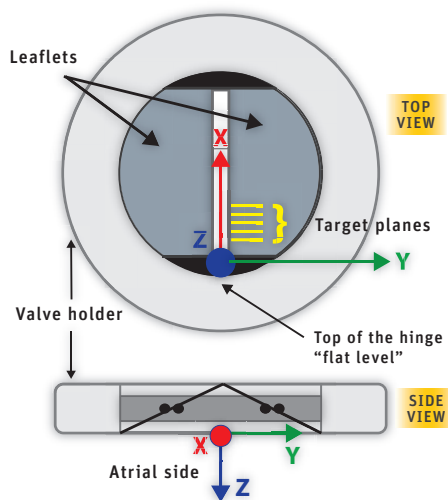

▲ CFD simulation for velocity distributions of leakage jet of bileaflet mechanical heart valve. Results on the left side are negative because the plane is on the negative side of the y-axis. COURTESY TECHNICAL UNIVERSITY OF CLUJ-NAPOCA, ROMANIA AND ISTITUTO SUPERIORE DI SANITÀ, ITALY.

## HEART VALVES

Today, physicians routinely replace damaged or deteriorated valves in the human heart. Now that the surgical challenges of the procedure are largely overcome, what remains is a complex engineering challenge: to design a valve prosthesis that matches the function and performance of a healthy heart valve. Bileaflet mechanical heart valves (BMHVs) are utilized often because they do not suffer from durability issues. However, they must satisfy certain characteristics, including backflow leakage during valve closure, which is vital for healthy valve dynamics. This backflow helps to prevent areas of stagnant flow and inhibits microthrombus (blood clot) formation. However, if the magnitude of shear stress due to the retrograde flow is too large, it can lead to platelet activation that causes blood clots or hemolysis (the abnormal breakdown of red blood cells).

To evaluate and optimize the effectiveness of a valve design requires analyzing its flow dynamics. However, it is challenging and time-consuming to obtain detailed measurements solely using in vitro methods. Computational fluid dynamics (CFD) allows researchers to study flow dynamics at high resolution,

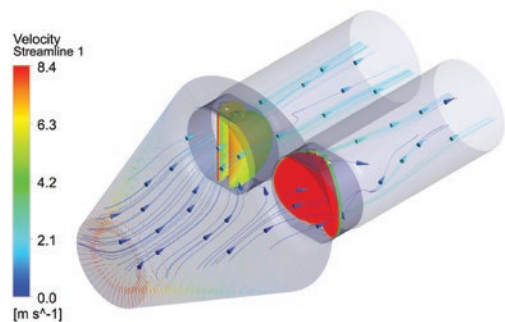

▲ Representation of flow field inside lumped parameter to 3-D coupled model of left heart and arterial system at peak systole (heart muscle contraction). This FSI model represents the movement of both the ventricular walls and the leaflets to investigate valve–valve interaction. COURTESY TECHNICAL UNIVERSITY OF CLUJ-NAPOCA, ROMANIA.

**With surgical challenges largely overcome, what remains is a complex engineering challenge – to design a valve prosthesis that matches the function and performance of a healthy heart valve.**

particularly in areas that are not visually accessible. Validation with experiments can be necessary to confirm that CFD results are accurate. MeDDiCA researchers have compared observations of the leakage jets for a BMHV obtained in experiments using particle image velocimetry, a method that measures velocities in fluid by taking two images shortly after each other, to findings from CFD predictions using ANSYS software. Researchers determined that comparison of CFD results to experiment is reasonable for the fully closed position of the valve.

Artificial valve function is driven by interaction between the blood (fluid) and the motion of the solid valve structure. Simulating the dynamic fluid–structure interaction (FSI) of heart valves is challenging, but, over the past decade, simulations have become increasingly realistic, evolving from conceptual 2-D geometries to patient-specific 3-D geometries. Research within MeDDiCA employs a novel multiscale model of mitral heart valve dynamics that incorporates features from the cellular level – the actin–myosin

cross-bridge cycle and calcium dynamics that give rise to the heart's beating. To specify boundary conditions, the model uses a geometrical multiscale approach that couples lumped-parameter models (of lower dimension) with 3-D models. Some features are modeled at a high level of detail (3-D domain), while the remaining part of the system is simplified to a lumped-parameter representation

Multiphysics and multiscale modeling allow FSI to be investigated in silico. Modeling helps to assess the fluid mechanics of prosthetic heart valves and to improve the design of these devices by minimizing the potential for blood clots and increasing valve durability. Implementation of moving mesh algorithms in ANSYS CFD software allows researchers to analyze fluid dynamics in a more realistic way compared to non-FSI simulations – for example, to provide information about valve leaflet motion during opening/closing stages and to determine dynamic leaflet stresses. By coupling a multiscale model of

left-ventricle contraction to a three-dimensional FSI model of a bileaflet mechanical heart valve, researchers can gain insight into the global biomechanics of the valve, leading to studies that investigate possible sources for hemolytic and cavitation drawbacks.

Researchers used coupling between 0-D models (MATLAB) and 3-D CFD models to exchange pressure and flow values. This multiscale, multiphysics model enables a more-detailed understanding of flow-induced stresses on valve mechanics based on physiological changes to pressures and flows. It allows researchers to study the influence of biological parameters and variables at various scales, and it also provides insight into underlying biological mechanisms that affect functionality of the mitral valve under both healthy and diseased conditions.

## STENTED VESSELS

Arterial restenosis is the recurrence of narrowing of a blood vessel (usually a coronary artery) after corrective surgery to



A



B

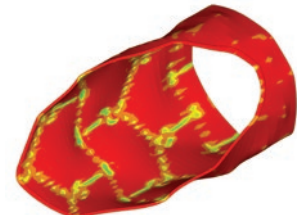

C

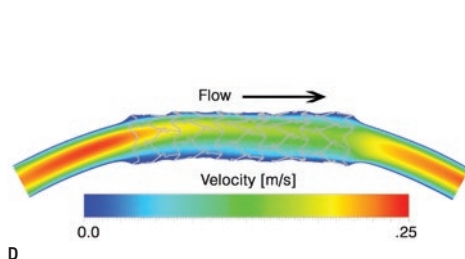

D

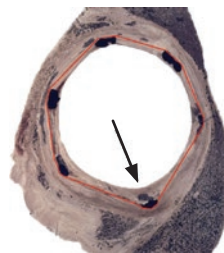

E

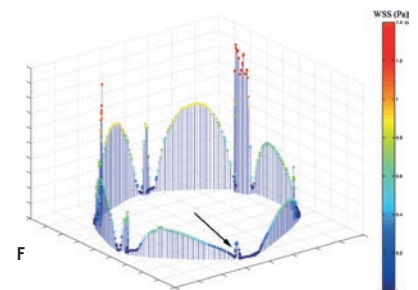

F

▲ Structural mechanics and fluid dynamics can be used to study the formation of thickened artery walls after a stent implant. A) Bare metal stent. B) Finite element model in initial configuration (7.5 mm length, 2.8 mm diameter cylinder) prior to radial expansion of vessel wall. After expansion and subsequent release of stent, C) stress contours on inner surface of vessel. D) Use of CFD to analyze coronary stent, implanted in porcine coronary artery and reconstructed from micro-CT, for identification of regions prone to formation of in-stent restenosis; velocity plotted on transversal plane of stented geometry. E) Comparison of histology to identical cross-section of numerical domain; traced red line depicts internal vessel structure, which corresponds with numerical model. Arrow indicates same position in histology F) numerical plot of wall-shear stress. COURTESY UNIVERSITY OF SHEFFIELD UK AND POLITECNICO DI MILANO, ITALY.

remove or reduce a previous narrowing (stenosis). It is a significant limitation for long-term success of endovascular interventions (minimally invasive surgery performed through major blood vessels) such as stent implants, in which a wire mesh is guided through the vessel to the location of a narrowing and expanded once in place to improve blood flow. In fact, despite improved success rates of stent implantation to relieve a thickened artery wall (an occlusive atherosclerotic lesion), acute inflammation of the vessel wall and resultant in-stent restenosis still occur in 20 percent of all bare-metal stent cases.

The severity of restenosis is associated with both initial injury of the arterial wall during stent deployment and subsequent biological response over time. Local fluid dynamics might affect the migration pattern of smooth muscle cells and endothelial cells that line the heart and blood vessels during initial healing stages, so wall-shear stress due to blood flow may be a potential accelerator. The interaction between the stent and the vessel is complex; it is challenging to study this process in vivo. Investigating the structural mechanics and fluid dynamics of stented vessels can give insight into the processes governing initiation and progression of restenosis. It also can provide guidance for optimizing stent design.

Placement of a stent into the artery changes both the structural and the hemodynamic environment of the vessel. Experimental techniques can be applied to study stent deformation in vitro, using stereo-optical methods to measure 3-D stent geometry. However, detailed experimental measurement of stress distribution within the vessel wall is not possible, so a finite element (or structural mechanics) model (FEM) is a powerful tool for studying changes in the artery's mechanical environment following stent implantation. Corresponding images of the tissue structure allow researchers to correlate the occurrence of restenosis and

vascular wall stress. Additionally, computational fluid dynamics of the altered vascular geometry after stent implantation provides very detailed information regarding flow domain, including local variations in wall-shear stress, which is impossible to measure experimentally in complex geometries and in vivo.

To examine structural and fluid dynamic changes following stent implantation along with their possible association with biological outcomes, researchers simulated a porcine right coronary artery using the in vivo stent geometry reconstructed from

micro-CT data (use of X-rays to determine the 3-D structure). Because corresponding tissue images were available, a direct correlation could be made with structural mechanics and CFD results. Using computational analyses, MeDDiCA researchers identified the regions of the stented artery that were subject to higher compressive stress and to a reduction in mean fluid wall-shear stress areas that may be more prone to formation of restenosis. By using stent geometry derived from in vivo data of an implanted stent, the availability of corresponding tissue data allows the

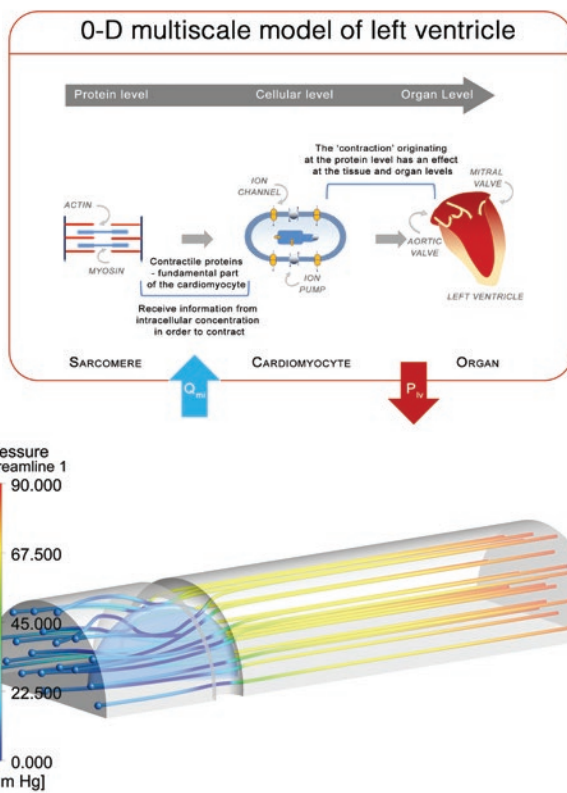

▲ A multiscale model of the heart is used to compute left ventricular pressure, which, in turn, is employed as a boundary condition for ANSYS CFX software using an immersed boundary approach to simulate the dynamics of the mitral valve. COURTESY UNIVERSITY COLLEGE LONDON.

## CFD of altered vascular geometry after stent implantation provides detailed information regarding the flow domain, which is impossible to measure experimentally.

mechanobiology of stent implantation to be explored in detail. Further studies of the relationship between localization of vascular wall stress, fluid dynamic parameters and in-stent restenosis will provide a deeper understanding of the phenomenon, leading to the identification of new design solutions and helping to guide developments in clinical techniques to unblock arteries.

### ACCESSING THE CIRCULATORY SYSTEM FOR HEMODIALYSIS

Because there is a lack of kidney donors, the majority of end-stage renal disease patients need to be treated with hemodialysis. This treatment uses an external machine to perform some kidney functions by circulating the patient's blood through it; therefore, it requires creating a permanent vascular access, typically obtained by connecting a vein onto an artery to form an arteriovenous fistula (AVF) into which a catheter can be inserted to connect to the hemodialysis machine. The hemodynamics inside the AVF is likely to induce several complications, but clinical tests are unable to determine which sites are more prone to cardiovascular problems. Modeling can help to answer clinical questions about local hemodynamic and structural stresses and their relationship with the onset of complications from AVF formation. The treatment of these complications can also be simulated.

MeDDiCA researchers have employed ANSYS fluid dynamics and structural mechanics software to study fluid-structure interactions within a patient-specific AVF that develops an arterial stenosis. The results highlight the regions of the vasculature that are more prone to complications due to altered hemodynamics and wall mechanics. The team also has numerically simulated treating the stenosis with two therapies: balloon angioplasty, with and without subsequent stenting. Comparing the results of the FSI simulations before and after treatment, the research team identified the influence of the stenosis on blood flow and wall stresses. Both treatments are equally effective in restoring the heart's work load, but stenting may help to prevent restenosis in the months following treatment by preventing contraction of the vessel.

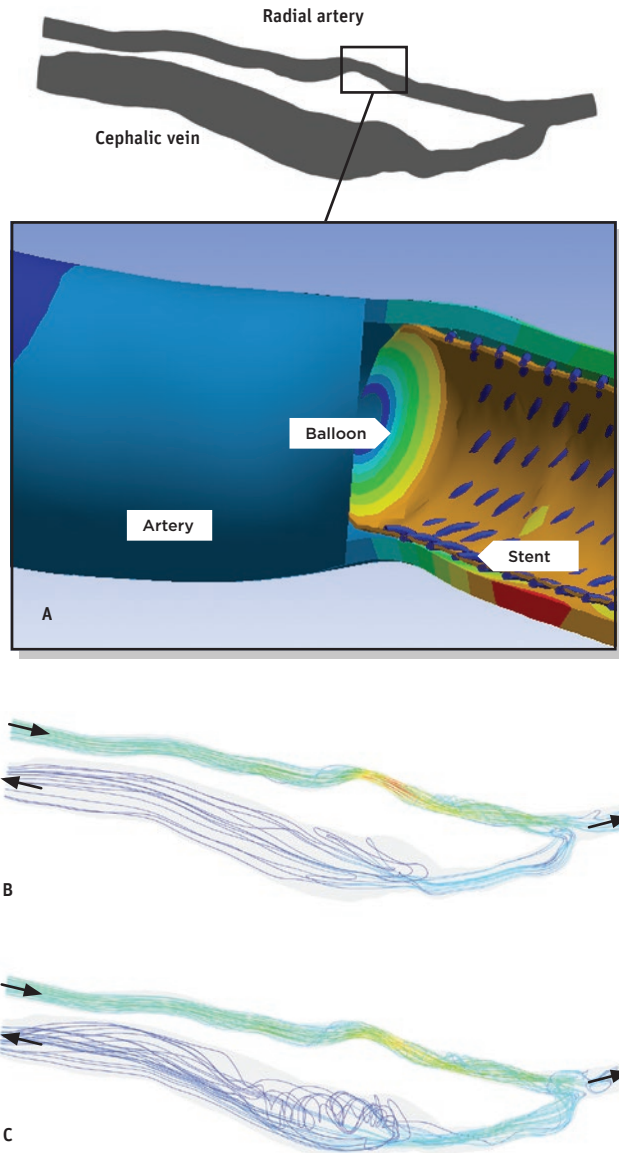

Geometry of patient-specific arteriovenous fistula; A) magnification shows ANSYS simulation of stent deployment following balloon angioplasty. B) Velocity streamlines at peak systole in stenosed patient-specific case and C) after endovascular treatment by balloon angioplasty. Notice that the treatment locally reduces maximum velocity value at the stenosis, but hardly impacts blood flow distribution farther downstream. COURTESY UTC-COMPIÈGNE, FRANCE.

### SIMULATION DELIVERS NEW MEDICAL INSIGHT

Modeling and simulation are well-established practices in the aeronautics and car manufacturing industries; the methods are an integral part of the design process. Similarly, these techniques are utilized to guide the design of medical devices, such as stents and artificial heart valves, by simulating their mechanical interaction with the vessel wall and blood flow dynamics. It is, however, more challenging

to model the biological interaction of medical devices with the vessel wall, especially as the disease evolves. Researchers should not think of these as merely biological problems, but rather as mechano-biological problems — the mechanical environment plays a governing role for the biology. Mechanical analyses play a vital role in understanding biology and predicting biological processes. State-of-the-art simulation models integrate observations, theories and

# These are not merely biological problems, they are mechanobiological problems – the mechanical environment plays a governing role for the biology.

predictions across a range of temporal and spatial scales, scientific disciplines and anatomical subsystems. Models that enable the cardiovascular system and its interactions to be investigated in silico can shed new light on phenomena observed in vitro and in vivo, assisting in the formulation and validation of new hypotheses and integration of novel, improved clinical tools to guide diagnosis and optimize personalized treatment. ANSYS software is already playing a vital role in such models and will play an increasingly important role in the future. ▲

## Author's Note

Contributors to this article include: **Paul Watton**, University of Oxford, U.K.; **Justin Penrose**, ANSYS; **Benjamin Bhattacharya Gosh** and **Vanessa Diaz**, University College London, U.K.; **Brandis Keller**, **Gabriele Dubini** and **Francesco Migliavacca**, Politecnico di Milano, Italy; **Claudia Maria Amatruda**, **Iwona Zwierzak** and **Andrew Narracott**, University of Sheffield, U.K.; **Iolanda Decorato** and **Anne-Virginie Salsac**, Université de Technologie de Compiègne, France; **Li Yan**, **Rajeev Kumar Nallamothu** and **Dan Rafiroiu**, Technical University of Cluj-Napoca, Romania; **Guanglei Wang Giuseppe D'Avenio** and **Mauro Grigioni**, Istituto Superiore di Sanità, Italy.

## References

MeDDiCA: [www.medica.eu](http://www.medica.eu)  
@neurIST: [www.aneurist.org](http://www.aneurist.org)  
GEMSS (IST-2001-37153): [www.gemss.de](http://www.gemss.de)  
COPHIT (IST-1999-14004)  
BloodSim (Esprit 28350)  
BREIN  
RT3S: [www.rt3s.eu](http://www.rt3s.eu)



## Automotive Simulation World Congress

Frankfurt am Main, Germany  
29 - 30 October 2013

[www.ansys.com/aswc](http://www.ansys.com/aswc)

# LEADER OF THE PACK

ANSYS HPC Parametric Pack licensing enables the quick solution of parametric simulations.

By Simon Pereira, Senior Product Manager, ANSYS, Inc.

The parametric setup and persistent update capabilities in ANSYS Workbench make it relatively easy to transition from one-off analyses to full parametric studies. The greatest obstacle to innovation then becomes the time required to run all the design points. One way to reduce that time is to solve multiple design points simultaneously. This simultaneous solve (first available in ANSYS 14.0) brought significant speedup over sequential execution, but each component checked out its own license. To update “n” design points simultaneously, you needed “n” times the licenses, which made running simultaneous design points cost-prohibitive for many ANSYS users. In addition, design points were prone to failure if not enough licenses were available throughout the update process.

In ANSYS 14.5, enhancements to parametric capabilities, including improved job scheduling, have made it easier to set up and manage parametric studies. The new HPC Parametric Pack licensing at version 14.5 offers a much more affordable and robust solution. This pack HPC solution allows you to run “n” design points simultaneously while drawing on only a single set of base licenses required by the project. The design points can include the execution of multiple products (pre-processing, meshing, solve, HPC, post-processing).

Once you understand how HPC parametric licensing works, you can use it to your advantage. HPC Parametric Pack, licensing requires a series of parametrically varying design points. This licensing cannot be used to run separate models at the same time; instead, it requires that you parameterize your model in ANSYS Workbench and then generate a design-point table with a series of parametric design variants. Fortunately, Workbench makes it relatively easy to parameterize many aspects of your model setup, including material properties, geometric dimensions, mesh controls, loads and boundary conditions.

**Workbench makes it relatively easy to parameterize many aspects of your model setup.**

## Scalable ANSYS HPC Parametric Packs

The HPC Parametric Pack solution is scalable. The first pack allows you to run four design points simultaneously ( $2 \times 2^1 = 4$ ), but each additional pack doubles the number of design points — for example, five packs give you  $2 \times 2^5 = 64$  simultaneous runs. Since HPC Parametric Packs also amplify the ANSYS HPC Packs, each simultaneous design point can further take advantage of parallel solver execution. These two dimensions of scalability have the potential to significantly compress execution time.

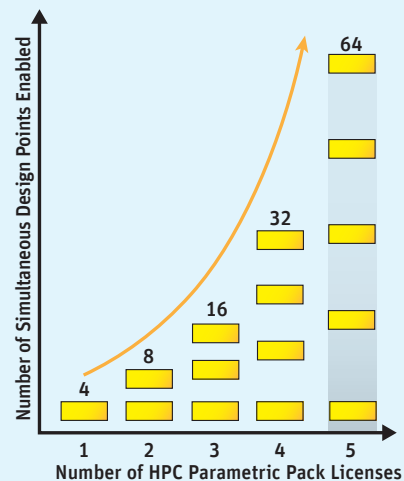

▲ Scalability of ANSYS HPC Parametric Packs



Even with the ANSYS Workbench advantage, parameterizing a model may still be challenging. If your geometry is not parametric or was badly parameterized in the CAD tool, you can use ANSYS SpaceClaim DirectModeler with its “direct modeling” ability to parameterize or reparameterize any imported geometry. You must also set up the model so that adjusting parameters within the range of interest will not “break” the model by causing the geometry update to fail or by making it difficult for the mesher or solver to converge. Applying best practices, such as clever use of named selections, can make your parametric model more robust. We recommend that you start with only a few parameters and less-complicated models before proceeding to a complex, highly parameterized study.

Once your model is parameterized, you could manually create a table of design points in Workbench to set up different parameter combinations. The design-point table also allows you to cut and paste a predefined design of experiments (DOE) from a third-party tool. If you want more-advanced robust design tools for sensitivity analysis, optimization or six sigma analysis, you could purchase ANSYS DesignXplorer or other third-party design exploration tools.

**Step 1: ANSYS HPC Parametric Packs apply only to a model parameterized through the Workbench parameter manager. Once a model is parameterized, a DOE can be imported or created manually, or you can use ANSYS DesignXplorer to create the design points for your project.**

HPC parametric licensing is enabled via the remote solve manager (RSM). The RSM already manages the individual jobs and gives you the ability to run design points simultaneously. Conveniently, RSM is also needed to send jobs to remote resources, including commercial job schedulers. ANSYS 14.5 significantly improves the capability, file transfer speed and robustness of RSM. The new wizard makes it much easier to perform setup for your HPC environment.

Properties of Schematic: Parameter Set	
A	B
Property	Value
Design Point Update Process	
Update Option	Submit to Remote Solve Manager
Pre-RSM Foreground Update	Geometry
License Checkout	Reserved
Reserved License Set	Select Licenses
Design Point Update Order	Update from Current
Job Submission	Specify Maximum Number of Jobs
Maximum Number of Jobs	4
Component Execution Mode	Parallel
Max Number of Processes Per Job	2
Keep Failed Design Point Files (Beta)	<input type="checkbox"/>
Solve Manager	localhost
Queue	Priority

▲ Remote solve manager setup for simultaneous design points is performed in the parameter set properties.

**Step 2: Adjust parameter set properties and switch the Update Option to Submit to Remote Solve Manager. Most users should set Individual Solver Update Options to Run in Foreground to send the entire design-point table to RSM and avoid resubmitting individual solver runs.**

The HPC Parametric Pack actually amplifies a “reserved set” of license keys. It is important to know which keys your project requires; the reserved licensing tools include a Used Keys tab that helps to determine which keys the project needs by showing which keys were used in previous runs. However, some ANSYS products can be enabled by any of a variety of keys. For example, an ANSYS Fluent simulation can use an ANSYS Fluent key or an ANSYS CFD key or an ANSYS Multiphysics key, depending on which is higher on your license preferences list. You can add keys to the reserved set directly from the Used Licenses tab, or you can browse to select your ANSYS CFD key for the reserved license set. ANSYS HPC Parametric Pack keys must be added to the reserved set. Once this is done, you will see the amplification shown in the number of available concurrent licenses. The reserved license set is held for a few minutes to give you a chance to start updating the series of design points. If you don’t do anything, you may need to check if your reserved set is still available. Once you start the update, the reserved set of licenses is held while the series of simulations is running and then automatically released at the end. Holding the set of keys for the duration of the parametric solve prevents others in your workgroup from taking any of the keys you required to complete your parametric simulation.

## Applying best practices can make your parametric model more robust. ▶

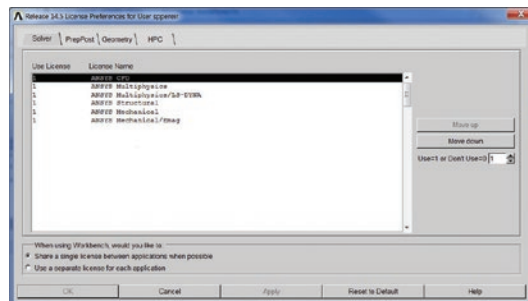

▲ License preferences determine which keys are drawn first by default, but the reserved set allows you to select the keys you want to use for the project.

**Step 3: Adjust parameter set properties to switch the License Checkout to Reserved. You then have the option to Select Licenses to be included in a specific reserved license set.**

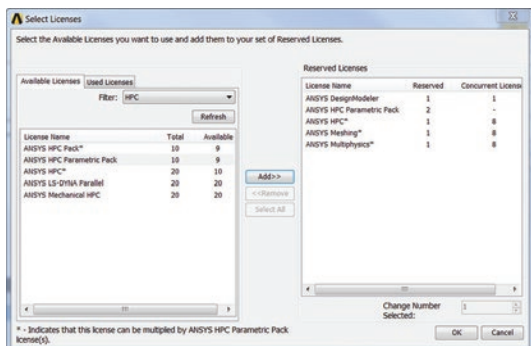

▲ Select the licenses to be included in a specific reserved license set.

**Step 4: Set up the correct reserved licenses and include your HPC keys and HPC parametric keys.**

Currently, ANSYS is able only to amplify keys that do not include third-party royalties. Keys for CAD readers, such as the Pro/ENGINEER interface or SpaceClaim, cannot be amplified even though they are used in your project. Similarly, ANSYS DesignModeler, which contains a parasolid kernel under license from a third party, cannot be amplified. When reserving licenses, you can identify keys that will be amplified by the asterisks (\*) next to their names.

Because these keys cannot be amplified, the geometry is updated in series as a Pre-RSM Foreground Update before running the meshing and other components in simultaneous mode. This also helps in cases in which CAD interfaces may not be licensed, installed or available on the remote computing resource, and it ensures that all the geometry updates are feasible upfront.

Even so, it is important to include these CAD interface or DesignModeler keys in the reserved license set even if they won't be amplified.

**Step 5: Even though keys used for pre-RSM geometry updates are not amplified by HPC Parametric Packs, you must include ANSYS DesignModeler and/or CAD interface keys in the reserved license set. These keys are used upfront during the Pre-RSM Foreground Update.**

The remaining process is the same as using RSM without HPC Parametric Packs. Always save your project before submitting to RSM because the process requires the saved files to run in batch mode. If you forget, your hardware reminds you. Once the update is running, you can monitor the progress through the applicable window in Workbench. The first feedback you see is the Pre-RSM Foreground Update that generates all the geometry files in serial. Once RSM starts, a simple RSM queue is shown, somewhat like a printer queue. You can launch the RSM utility to give you much more detail for each job and to follow messages that track the progress of each job. When RSM is complete, the reserved license set is automatically released along with the new ANSYS HPC Parametric Pack keys. ▲

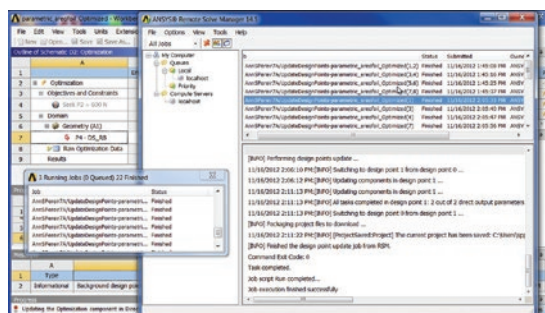
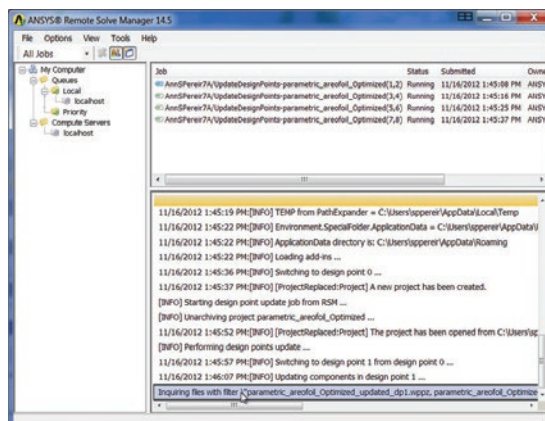

▲ RSM allows you to monitor the jobs and diagnose any problems that arise both early (top) and later in the run (bottom).

## Using Other Design Exploration Tools

Using ANSYS HPC Parametric Packs with a third-party design exploration tool requires that the tools be Workbench integrated, drive parametric updates via the Workbench parametric set, and execute the design points through ANSYS RSM. At time of writing, optiSlang from Dynardo GmbH has been confirmed compatible with ANSYS HPC Parametric Packs, and other optimization partners are working on this functionality.

**When Silicon Valley needs difficult simulations done...**

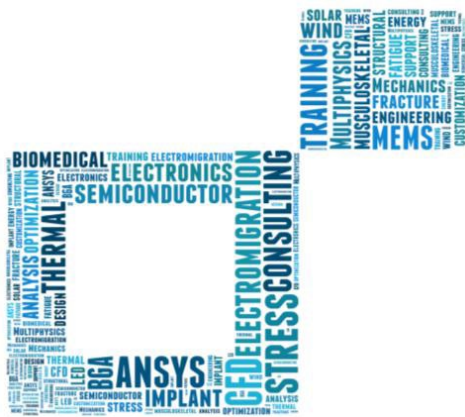

# Ozen

*Problem Solved.*



[www.ozeninc.com](http://www.ozeninc.com)

(408) 732-4665

## Innovation Stressing your IT Infrastructure?

*Accelerate design & simulation applications with technical computing clusters*

Learn how clusters and the right cluster and workload management software can improve your business with this FREE download of Clusters for Dummies ebook

[ibm.com/platformcomputing](http://ibm.com/platformcomputing)

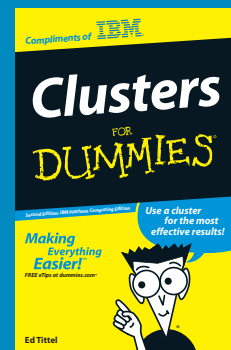

ANSYS, Inc.  
Southpointe  
275 Technology Drive  
Canonsburg, PA U.S.A. 15317

Send address corrections to  
[AdvantageAddressChange@ansys.com](mailto:AdvantageAddressChange@ansys.com)

# A Winning Formula

*Infiniti Red Bull Racing and ANSYS*



Victories by Infiniti Red Bull Racing. Simulation by ANSYS.

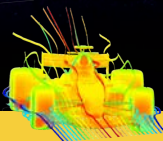

# ANSYS®

Realize Your Product Promise®

Winning the Formula One World Constructors' Championship is a monumental accomplishment. Winning it three times in a row is practically unheard of. But for Infiniti Red Bull Racing, it was just another day at the office.

Using ANSYS simulation technology, Infiniti Red Bull Racing is creating virtual prototypes of its race cars, so engineers can quickly and inexpensively optimize everything from aerodynamics to brakes to exhaust systems. Infiniti Red Bull Racing is delivering on its product promise by remaining dominant in one of the most competitive environments imaginable.

Not a bad day at the office.



Visit [ANSYS.COM/InfinitiRedBullRacing](http://ANSYS.COM/InfinitiRedBullRacing) to learn how simulation software can help you realize your product promise.